

DEPARTMENT OF THE ARMY TECHNICAL MANUAL

DIRECT SUPPORT, GENERAL SUPPORT, AND DEPOT
MAINTENANCE REPAIR PARTS AND SPECIAL
TOOLS LIST

TELESCOPE PANORAMIC M12A7C

(1240-768-7260), M12A7H (1240-344-4633),

M12A7K (1240-344-4632),

M12A7Q (1240-917-6428) and

M12A7S (1240-344-6433)

HEADQUARTERS, DEPARTMENT OF THE ARMY

JULY 1970

TECHNICAL MANUAL }
No. 9-1240-236-35P }

HEADQUARTERS
DEPARTMENT OF THE ARMY
WASHINGTON, D.C. 9 July 1970

DIRECT SUPPORT, GENERAL SUPPORT, AND DEPOT MAINTENANCE

REPAIR PARTS AND SPECIAL TOOLS LIST

**TELESCOPE PANORAMIC M12A7C (1240-768-7260),
M12A7H (1240-344-4633), M12A7K (1240-344-4632),
M12A7Q (1240-917-6428) and M12A7S (1240-344-6433)**

Section		Paragraph	Page
	I. INTRODUCTION		
	Scope . -----	1	2
	General -----	2	2
	Explanation of columns -----	3	2
	Special Information -----	4	3
	How to locate repair parts -----	5	4
	Abbreviations -----	6	4
	Federal supply codes for manufacturers -----	7	5
	Recommendations for maintenance publications -----	8	5
II.	REPAIR PARTS FOR DIRECT SUPPORT, GENERAL SUPPORT, AND DEPOT MAINTENANCE -----		7
III.	SPECIAL TOOLS, TEST AND SUPPORT EQUIPMENT FOR DIRECT SUPPORT, GENERAL SUPPORT, AND DEPOT MAINTENANCE -----		51
IV.	INDEX-FEDERAL STOCK NUMBER AND REFERENCE NUMBER CROSS-REFERENCE TO FIGURE AND ITEM NUMBER -----		52

*This manual supersedes TM 9-1240-236-35P, 7 Sept 62, including all changes.

SECTION I. INTRODUCTION

1. Scope

This manual lists repair parts, special tools, and equipment required for the performance of direct support, general support, and depot maintenance of the Telescope Panoramic M12A7C, M12A7H, M12A7K, M12A7Q and M12A7S.

2. General

This Repair Parts and Special Tools List is divided into the following sections:

a. *Repair Parts-Section II.* A list of repair parts for the performance of maintenance at the direct support, general support, and depot level in figure and item number sequence.

b. *Special Tools, Test and Support Equipment -Section III.* A list of special tools, test and support equipment for the performance of maintenance at the direct support, general support, and depot level.

c. *Federal Stock Number and Reference Number Index-Section IV.* A list of Federal Stock Numbers in ascending sequence followed by a list of reference numbers in ascending alpha-numeric sequence, cross-referenced to the illustration figure number and item number.

3. Explanation of Columns

The following provides an explanation of columns in the tabular lists in Sections II and III.

a. *Source Maintenance and Recoverability Codes (SMR), Column 1:*

(1) Source code, indicates the selection status and source for the listed item. Source codes are:

<i>Code</i>	<i>Explanation</i>
P	Repair parts, special tools, and test equipment which are stocked in or supplied from the GSA/DSA, or Army supply system and authorized for use at indicated maintenance categories.
P2	Repair parts, special tools, and test equipment which are procured and stocked for insurance purposes because the combat or military essentiality of the end items dictates that a minimum quantity be available in the supply system.
P9	Assigned to items which are NSA design controlled; unique repair parts, special tools, test, measuring and diagnostic equipment, which are stocked and supplied by the Army Comsec logistic system, and which are not subject to the provisions of AR 380-41.

<i>Code</i>	<i>Explanation</i>
P10	Assigned to items which are NSA design controlled; special tools, test, measuring and diagnostic equipment for Comsec support, which are accountable under the provision of AR 380-41, and which are stocked and supplied by the Army Comsec logistic system.
M	Repair parts, special tools and test equipment which are to be manufactured at indicated maintenance levels.
A	Assemblies which are not procured or stocked as such, but are made up of two or more units. Such component units carry individual stock numbers and descriptions, are procured and stocked separately and can be assembled to form the required assembly at indicated maintenance categories.
X	Parts and assemblies which are not procured or stocked and the mortality of which normally is below that of the applicable end item or component. The failure of such part or assembly should result in retirement of the end item from the supply system.
X1	Repair parts which are not procured or stocked. The requirements for such items will be filled by use of the next higher assembly or component.
X2	Repair parts, Special Tools and Test Equipment which have no foreseen mortality. The indicated maintenance category requiring such repair part will attempt to obtain same through cannibalization and/or salvage. When such items are not obtainable through cannibalization or salvage, the item may be requisitioned with accompanying justification, through normal supply channels.
G	Major assemblies that are procured with PEMA funds for initial issue only as exchange assemblies at DSU and GSU level. These assemblies will not be stocked above DS and GS level or returned to depot supply level.

(2) Maintenance code, indicates the lowest category of maintenance authorized to install the listed item. The maintenance level codes are:

<i>Code</i>	<i>Explanation</i>
C	Crew or operator maintenance
O	Organizational maintenance
F	Direct support maintenance
H	General support maintenance
D	Depot maintenance.

(3) Recoverability Codes. The following codes will be used when the responsible Army activity desires the return of unserviceable repair parts, special tools and test equipment:

<i>Code</i>	<i>Explanation</i>
R	Applies to repair parts (assemblies and components) special tools and test equipment which are considered economically repairable at direct and general support maintenance levels. When the item

Code	Explanation
	is no longer economically repairable it is normally disposed of at the GS level. When supply considerations dictate, some of these repair parts may be listed for automatic return to supply for depot level repair as set forth in AR 710-50. When so listed, they will be replaced by supply on an exchange basis.
S	Repair parts, special tools, test equipment and assemblies which are economically repairable at DSU and GSU activities and which normally are furnished by supply on an exchange basis. When items are determined by a GSU to be uneconomically repairable, they will be evacuated to a depot for evaluation and analysis before final disposition.
T	High dollar value recoverable repair parts, special tools and test equipment which are subject to special handling and are issued on an exchange basis. Such items will be evacuated to the depot for overhaul or final disposition. This criteria is interpreted as including items like engines even though minor adjustments/repairs are authorized at below depot level. Communications-Electronics and Missile Support Items will be repaired/overhauled only at depots.
U	Repair parts, special tools and test equipment specifically selected for salvage by reclamation units because of precious metal content, critical materials, high dollar value or reusable casings or castings.

each item, is the total quantity of items authorized for the number of equipments supported. Subsequent appearances of the same item will have the letters "REF" in the applicable allowance columns. Items authorized for use as required but not for initial stockage are identified with an asterisk in the allowance column.

(2) The quantitative allowances for DS/GS levels of maintenance will represent initial stockage for a 30-day period for the number of equipments supported.

(3) Determination of the total quantity of parts required for maintenance of more than 100 of these equipments can be accomplished by converting the equipment quantity to a decimal factor by placing a decimal point before the next to last digit of the number to indicate hundredths, and multiplying the decimal factor by the parts quantity authorized in the 51-100 allowance column. Example, authorized allowance for 51-100 equipments is 40; for 150 equipments multiply 40 by 1.50 or 60 parts required.

g. 1-Year Allowances Per 100 Equipment/Contingency Planning Purposes, Column 8. This column indicates opposite the first appearance of each item the total quantity required for distribution and contingency planning purposes. The range of items indicates total quantities of all authorized items required to provide for adequate support of 100 equipments for one year.

h. Depot Maintenance Allowance Per 100 Equipments, Column 9. This column indicates opposite the first appearance of each item, the total quantity authorized for depot maintenance of 100 equipments. Subsequent appearances of the same item will have the letters "REF" in the allowance column. Items authorized for use as required but not for initial stockage are identified with an asterisk in the allowance column.

i. Illustration, Column 10. This column is divided as follows:

(1) *Figure Number Column 10a.* Indicates the figure number of the illustration in which the item is shown.

(2) *Item Number Column 10b.* Indicates the callout number used to reference the item in the illustration.

4. Special information

a. Action change codes indicated in the left hand margin of the listing page denote the following:

N-Indicates an added item not included in previous publications.

C-Indicates a change in data.

F-Indicates a change in FSN only.

b. Federal Stock Number, Column 2. This column indicates the Federal Stock Number assigned to the item and will be used for requisitioning purposes.

c. Description, Column 3. This column indicates the Federal item name and any additional description of the item required. The abbreviation "w/e" when used as a part of the nomenclature, indicates the Federal stock number includes all armament, equipment, accessories, and repair parts issued with the item. A part number or other reference number is followed by the applicable five-digit Federal supply code for manufacturers in parentheses.

d. Unit of Measure (U/M), Column 4. A 2 character alphabetic abbreviation indicating the amount or quantity of the item upon which the allowances are based e.g., ft, ea, pr, etc.

e. Quantity Incorporated in Unit, Column 5. This column indicates the quantity of the item used in the assembly or the portion illustrated. A "V" appearing in this column in lieu of a quantity indicates that a definite quantity cannot be indicated, (e.g., shims, spacers, gaskets, etc.).

f. 30-Day DS/GS Maintenance Allowances, Columns 6 and 7.

Note: Allowances in GS column are for GS maintenance only.

(1) The allowance columns are divided into three subcolumns. Indicated in each subcolumn, opposite the first appearance of

b. The following publications pertain to Telescope Panoramic and its components:

M12A7C

TM 9-1025-200-20P Organizational Maintenance Repair Parts, and Special Tools Lists for Howitzer, Medium Towed, 155MM M114 and M114A1 and Howitzer, Medium Towed, Auxiliary Propelled 155MM M123A1.

TM 9-1055-205-20P Organizational Maintenance Repair Parts, and Special Tools Lists Truck Mounted 762MM Rocket Launcher M386.

M12A7H

TM 9-1015-203-20P Organizational Maintenance Repair Parts, and Special Tools List 105MM Towed Light Howitzer M101 and M101A1.

M12A7K

TM 9-2350-203-20P Organizational Maintenance Repair Parts, and Special Tools Lists for Howitzer Self-Propelled, Full Tracked 155MM, M44 and M44A1.

M12A7Q

TM 9-1025-200-20P Organizational Maintenance Repair Parts, and Special Tools Lists for Howitzer Medium Towed, 155MM M114 and M114A1 and Howitzer, Medium Towed, Auxiliary Propelled 155MM M123A1.

M12A7S

TM 9-1015-203-20P Organizational Maintenance Repair Parts, and Special Tools List 105MM Towed Light Howitzer M101 and M101A1.

c. To maintain disassembly sequence in this manual, a sequence number in parentheses will be displayed immediately to the right of the callout number on the illustration.

d. Identifications of the usable on codes included in column 3 of this publication are:

Code	Explanation
A	M12A7C
B	M12A7H
C	M12A7K
D	M12A7Q
E	M12A7S

5. How to Locate Repair Parts

a. When Federal Stock Number or reference number is unknown:

(1) *First.* Find the illustration covering the assembly group to which the repair part belongs.

(2) *Second.* Identify the repair part on the illustration and note the illustration figure and item number of the repair part.

(3) *Third.* Using the Repair Parts Listing, find the assembly group to which the repair part belongs and locate the illustration figure and item number noted on the illustration.

b. When Federal Stock number or reference number is known:

(1) *First.* Using the Index of Federal Stock Numbers and Reference Numbers find the pertinent Federal Stock number or reference number. This index is in ascending FSN sequence followed by a list of reference numbers in ascending alpha-numeric sequence, cross-referenced to the illustration figure number and item number.

(2) *Second.* Using the Repair Part Listing find the assembly group of the repair part and the illustration figure number and item number referenced in the Index of Federal Stock Numbers and Reference Numbers.

6. Abbreviations

Abbreviations	Explanation
aly	alloy
blk	block
brs	brass
cd pl	cadmium plate
ck	cork
cp	cone point
cres	corrosion resistant steel
cs	case
cskh	countersunk head
dia	diameter
filh	filister head
fl	flat
fp	flat point
fnsh	finish
hdls	headless
hex	hexagon
id	inside diameter
l	long
muw	music wire
no.	number
od	outside diameter
oxd	oxide

<i>Abbreviations</i>	<i>Explanation</i>
pld -----	plated
pnh -----	panhead
psvt -----	passivate
rbr -----	rubber
rec -----	recess
skt -----	skirt
sltd -----	slotted
stk -----	stock
stl -----	steel
thk -----	thick
unc -----	unified course thread
unf .-----	unified fine thread

7. Federal Supply Codes for Manufacturers

<i>Code</i>	<i>Manufacturer</i>
10001	Naval Ordnance Systems Command Washington, D.C. 20360
19200	Frankford Arsenal, Philadelphia, Pa.
21450	Ordnance Corps Engineering Standards, Rock Island Arsenal, Rock Island, Ill.
96906	Military Standard Promulgated by Standardization Division, Directorate of Logistic Services DSA

8. Recommendations for Maintenance Publication Improvements

Report of errors, omissions, and recommendations for improving this publication by the individual user is encouraged. Reports should be submitted on DA Form 2028 (Recommended Changes to DA Publications) and forwarded direct to The Commanding Officer, Frankford Arsenal, ATTN: AMSWE-SMF-W3100, Philadelphia, Pa. 19137.

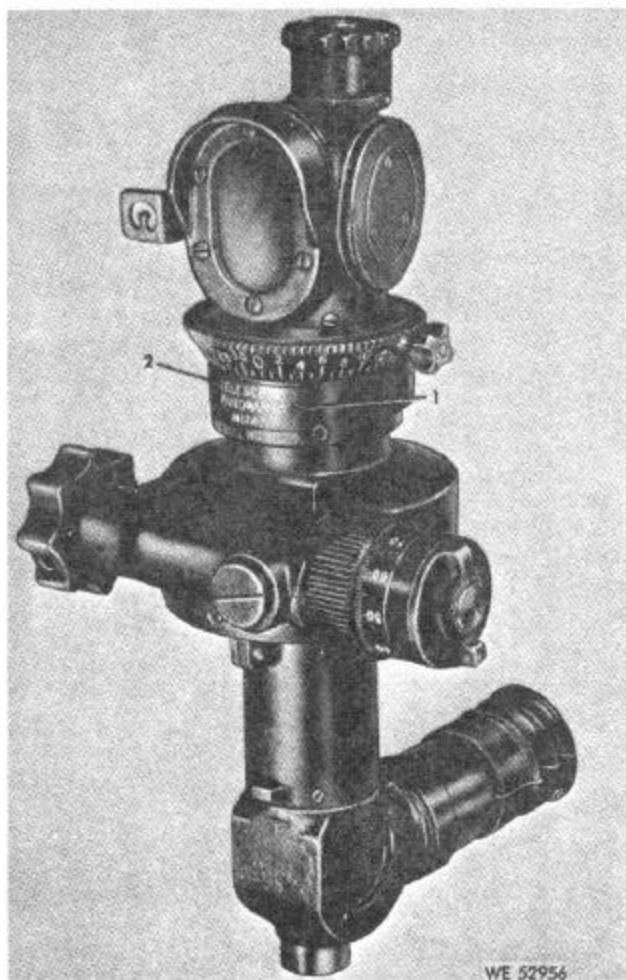
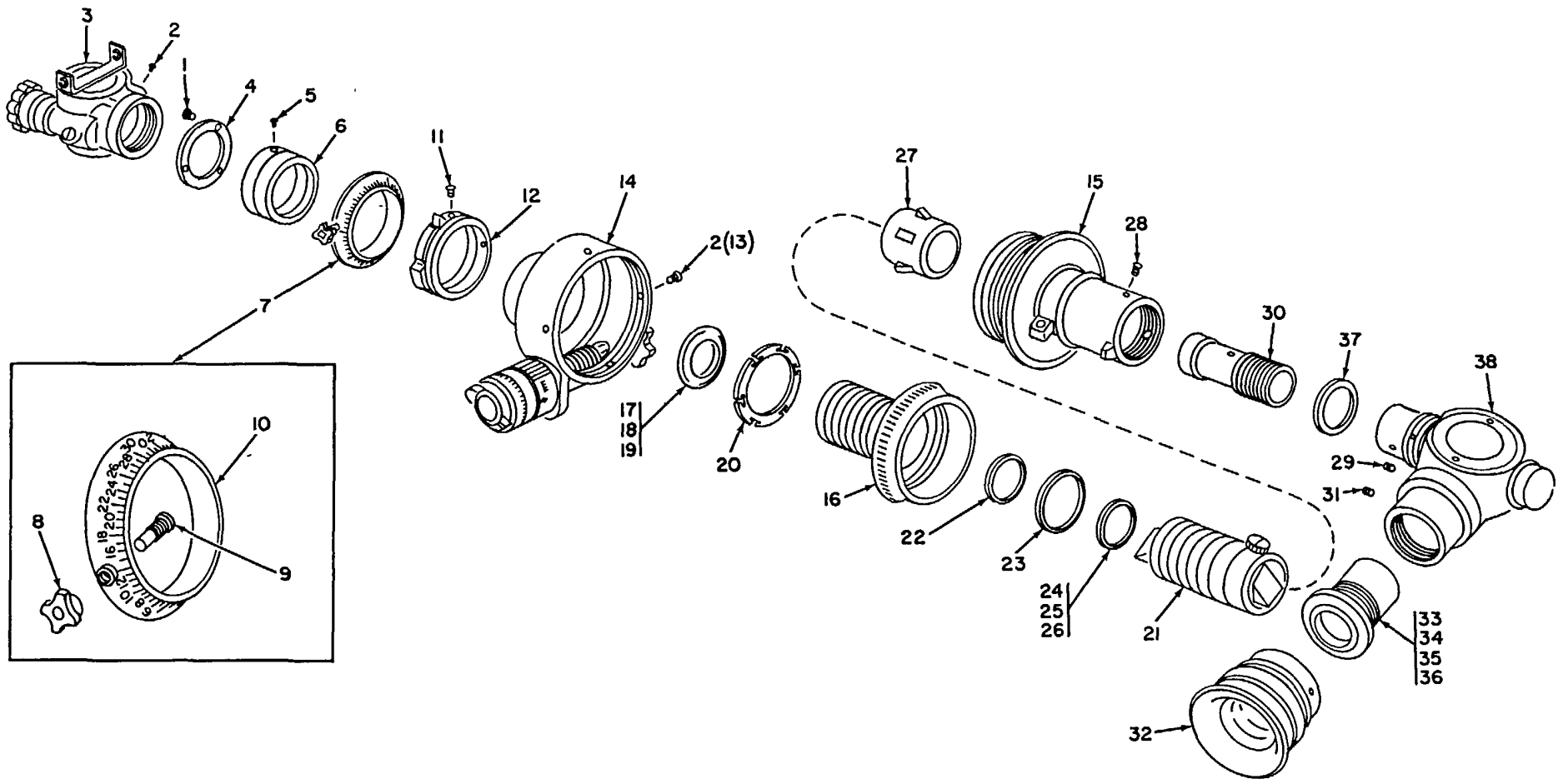

Figure 1. Telescopic Panoramic M12A7C-7668760, M12A7H-8243177, M12A7K-822975, M12A7Q-8213035, and M12A7S-8213037.

**SECTION II. REPAIR PARTS FOR DIRECT SUPPORT,
GENERAL SUPPORT AND DEPOT MAINTENANCE**

ACT ON CODE	(1) SOURCE, MAINT, AND RECOV. CODE			(2) FEDERAL STOCK NO.	(3) DESCRIPTION Reference Number & Mfr Code Usable On Code	(4) UNIT OF MEAS	(5) QTY INC. IN UNIT	(6) 30-DAY DS MAINT. ALLOWANCE			(7) 30-DAY GS MAINT. ALLOWANCE			(8) 1YR. ALW PER 100 EQUIP. CNTGNCY	(9) DEPOT MAINT. ALW PER 100 EQUIP.	(10) ILLUSTRATION	
	(A) SOURCE	(B) MAINT.	(C) RECOV.					(A) 1-20	(B) 21-50	(C) 51-100	(A) 1-20	(B) 21-50	(C) 51-100			(A) FIG. NO.	(B) ITEM NO.
	N	P-	F-						6306-064-5635	TELESCOPE, PANORAMIC M12A7C-7687260 M12A71-8243177 M12A7K-8228975 M12A7Q-8213035 M12A7S-8213037	EA	2	*			1	2
N	P-	F-		9905-191-7213	SCREW, MACHINE PNH, CROSS REC, CRES, PSVT FNSH, NO. 2 56UNC-2A, 1/8 L MS51967-1 (96906)	EA	1	*	1	1	*	1	1	12	5	1	12



WE 52957

Figure 2. Telescope, panoramic-partial exploded view.

ACT ON CODE	(1) SOURCE, MAINT, AND RECOV. CODE			(2) FEDERAL STOCK NO.	(3) DESCRIPTION Reference Number & Mfr Code Usable On Code	(4) UNIT OF MEAS	(5) QTY INC. IN UNIT	(6) 30-DAY DS MAINT. ALLOWANCE			(7) 30-DAY GS MAINT. ALLOWANCE			(8) 1YR. ALW PER 100 EQUIP. CNTGCV	(9) DEPOT MAINT. ALW PER 100 EQUIP.	(10) ILLUSTRATION	
	(A) SOURCE	(B) MAINT.	(C) RECOV.					(A) 1-20	(B) 21-50	(C) 51-100	(A) 1-20	(B) 21-50	(C) 51-100			(A) FIG. NO.	(B) ITEM NO.
N	P-	F-		5305-781-9479	SCREW, MACHINE FL CSKH, CROSS REC, BRS, BLK OXD, NO. 2 64UNF-2A, 1/8 L MS35199-1 (96906)	EA	3	*	1	1	*	1	1	12	5	2	1
N	P-	F-		5305-774-9704	SCREW, MACHINE FL CSKH, CROSS REC, CRES, PSVT FNSH, NO. 2 64UNF-2A, 3/16 L MS51960-7 (96906)	EA	8	*	1	2	*	1	2	24	10	2	2
N	X--			-----	HEAD ASSEMBLY 7687277 (19200)	-----	1	-----	-----	-----	-----	-----	-----	-----	-----	2	3
N	X--			-----	RING 7654658 (19200)	-----	1	-----	-----	-----	-----	-----	-----	-----	-----	2	4
N	P-	H-		5305-050-3944	SCREW 503944 (19200)	EA	4	-----	-----	-----	*	1	2	24	10	2	5
N	X--			-----	SCALE 7687282 (19200)	-----	1	-----	-----	-----	-----	-----	-----	-----	-----	2	6
N	P-	H-		1240-114-1081	SCALE ASSEMBLY 7687283 (19200)	EA	1	-----	-----	-----	*	1	1	12	5	2	7
C	X1--			-----	KNOB 7687291 (19200)	-----	1	-----	-----	-----	-----	-----	-----	-----	-----	2	8

ACT ON CODE	(1) SOURCE, MAINT, AND RECOV. CODE			(2) FEDERAL STOCK NO.	(3) DESCRIPTION Reference Number & Mfr Code Usable On Code	(4) UNIT OF MEAS	(5) QTY INC. IN UNIT	(6) 30-DAY DS MAINT. ALLOWANCE			(7) 30-DAY GS MAINT. ALLOWANCE			(8) 1YR. ALW PER 100 EQUIP. CNTGCTY	(9) DEPOT MAINT. ALW PER 100 EQUIP.	(10) ILLUSTRATION	
	(A) SOURCE	(B) MAINT.	(C) RECOV.					(A) 1-20	(B) 21-50	(C) 51-100	(A) 1-20	(B) 21-50	(C) 51-100			(A) FIG. NO.	(B) ITEM NO.
C	X1--				SCREW, LOCK BRS, FLH, 0.164-36NF-3A, 0.77 L 7687292 (19200)		1									2	9
N	X1--				SCALE 7687279 (19200)		1									2	10
N	P-	H-		5305-724-72765	SETSCREW HEX SKT, FP, ALY STL, CD PL, NO. 6 40UNF-3A, 1/8 L MS51966-25 (96906)	EA	4			*	1	1	12	5	2	11	
C	P-	H-		1240-768-7280	COLLAR ASSEMBLY (RVT) 7687280 (19200)	EA	1			*	1	2	24	10	2	12	
N	X--				HOUSING ASSEMBLY 7687285 (19200)		1								2	14	
N	X--				SHANK ASSEMBLY 7636577 (19200)		1								2	15	
C	P-	H-		1240-763-6238	GEAR ASSEMBLY 7636238 (19200)	EA	1			*	1	2	24	10	2	16	
N	P-	H-		5365-182-9811	SHIM, STEEL (.003 THK) 10555984-1 (19200)	EA	V			*	1	1	12	5	2	17	

N	P-	H-	5365-182-9812	SHIM, STEEL (.004 THK) 10555984-2 (19200)	EA	V	----	----	----	*	1	1	12	5	2	18
N	P-	H-	5365-182-9813	SHIM, STEEL (.005 THK) 10555984-3 (19200)	EA	V	----	----	----	*	1	1	12	5	2	19
C	P-	H-	5310-639-7660	WASHER, SPRING TENSION STL, 1.44 ID, 2.025 OD, 0.105 THK 5049938 (19200)	EA	1	----	----	----	*	1	1	12	5	2	20
N	P-	H-	1240-622-4405	PRISM, OPTICAL INSTRUMENT 7635302 (19200)	EA	1	----	----	----	*	1	1	12	5	2	21
N	P-	H-	5365-182-9814	SHIM 10555983-1 (19200)	EA	V	----	----	----	*	1	1	12	5	2	22
C	P-	H-	1240-765-0547	SPRING, TUBULAR STL, 1.136 ID, 1.260 OD, 0.130 THK 7650547 (19200)	EA	1	----	----	----	*	1	1	12	5	2	23
N	P-	H-	6365-182-9815	SHIM, STEEL (.009 THK) 10555983-2 (19200)	EA	V	----	----	----	*	1	1	12	5	2	24
N	P-	H-	5365-182-9817	SHIM, STEEL (.010 THK) 10555983-3 (19200)	EA	V	----	----	----	*		1	12	5	2	25
N	P-	H-	5365-182-9818	SHIM, STEEL (.015 THK) 10555983-4 (19200)	EA	V	----	----	----	*	1	1	12	5	2	26
C	P-	H-	1240-757-7823	GUARD 7577823 (12900)	EA	1	----	----	----	*	1	2	24	10	2	27

ACT ON CODE	(1) SOURCE, MAINT. AND RECOV. CODE			(2) FEDERAL STOCK NO.	(3) DESCRIPTION Reference Number & Mfr Code Usable On Code	(4) UNIT OF MEAS	(5) QTY INC. IN UNIT	(6) 30-DAY DS MAINT. ALLOWANCE			(7) 30-DAY GS MAINT. ALLOWANCE			(8) 1YR. ALW PER 100 EQUIP. CNTGCV	(9) DEPOT MAINT. ALW PER 100 EQUIP.	(10) ILLUSTRATION	
	(A) SOURCE	(B) MAINT.	(C) RECOV.					(A) 1-20	(B) 21-50	(C) 51-100	(A) 1-20	(B) 21-50	(C) 51-100			(A) FIG. NO.	(B) ITEM NO.
N	P-	H-		5305-701-5230	SCREW, MACHINE FL CSKH, CROSS REC, CRES, PSVT FNSH, NO. 2 64UNF-2A, 1/4 L MS51960-8 (96906)	EA	4	----	----	----	*	1	2	24	10	2	28
C	P-	H-		5305-057-1631	SETSCREW HEX SKT, CP, CRES, PSVT FNSH, NO. 2 64UNF-3A, 5/32 L MS51038-17 (96906)	EA	1	----	----	----	*	1	2	24	10	2	29
N	A--				OBJECTIVE ASSEMBLY 7635305 (19200)	----	1	----	----	----	----	----	----	----	----	2	30
C	P-	H-		5305-081-2651	SETSCREW HEX SKT, CP, CRES, PSVT FNSH, NO. 2 64UNF-3A, 3/32 L MS51038-15 (96906)	EA	1	----	----	----	*	1	2	24	10	2	31
C	P-	O-		1240-504-9940	EYESHIELD, OPTICAL INSTRU- MENT 5049940 (19200)	EA	1	1	1	2	1	1	2	24	15	2	32
N	X--				EYEPIECE ASSEMBLY 7687266 (19200)	A,C	1	----	----	----	----	----	----	----	----	2	33
N	X--				EYEPIECE ASSEMBLY 8243176 (19200)	B	1	----	----	----	----	----	----	----	----	2	34
N	X--				EYEPIECE ASSEMBLY 8289215 (19200)	E	1	----	----	----	----	----	----	----	----	2	35

N	X--		EYEPIECE ASSEMBLY 8570118 (19200)	D	----	1	----	----	----	----	----	----	----	----	2	36
N	P- H-		PACKING 8624876-1 (19200)	EA		1	----	----	----	*	1	1	12	5	2	37
N	X--		ELBOW ASSEMBLY 7199579 (19200)		----	1	----	----	----	----	----	----	----	----	2	38

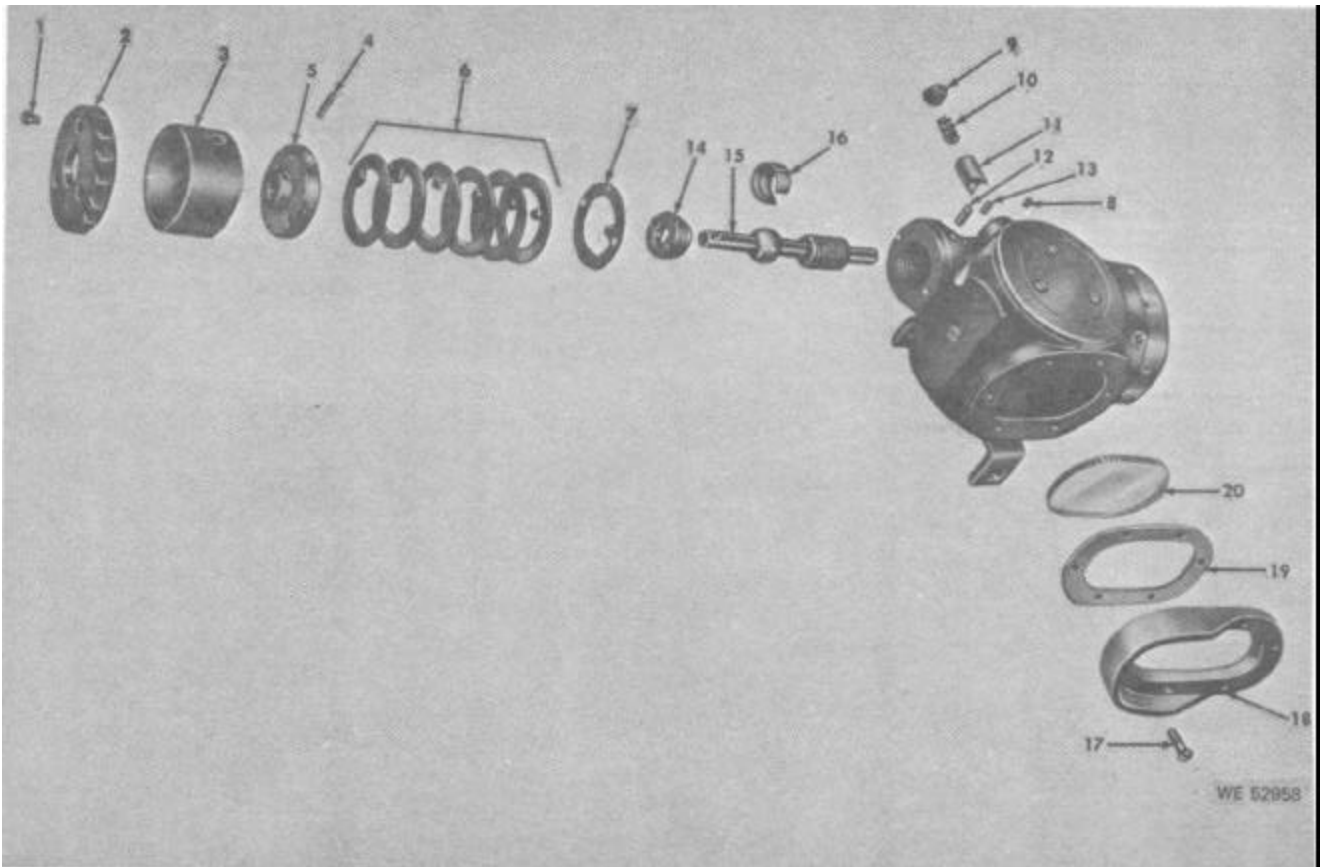

Figure 3. Head, assembly 7687277-partial exploded view.

ACT ON CODE	(1) SOURCE, MAINT, AND RECOV. CODE			(2) FEDERAL STOCK NO.	(3) DESCRIPTION Reference Number & Mfr Code Usable On Code	(4) UNIT OF MEAS	(5) QTY INC. IN UNIT	(6) 30-DAY DS MAINT. ALLOWANCE			(7) 30-DAY GS MAINT. ALLOWANCE			(8) 1YR. ALW PER 100 EQUIP. CNTGCTY	(9) DEPOT MAINT. ALW PER 100 EQUIP.	(10) ILLUSTRATION	
	(A) SOURCE	(B) MAINT.	(C) RECOV.					(A) 1-20	(B) 21-50	(C) 51-100	(A) 1-20	(B) 21-50	(C) 51-100			(A) FIG. NO.	(B) ITEM NO.
N	P-	F-	5305-912-7656	SCREW, MACHINE DRILLED FILH, SLTD, CRES, PSVT FNSH, NO. 2 645UNF-2A, 1/8 L MS35276-201 (96906)	EA	3	*	1	2	*	1	2	24	10	3	1	
N	P-	F-	5355-667-9382	KNOB 5049927 (19200)	EA	1	*	1	2	*	1	2	24	10	3	2	
C	P-	F-	5355-504-9926	MICROMETER----- 5049926 (19200)	EA	1	*	1	2	*	1	2	24	10	3	3	
C	P-	H-	5315-187-3226	PIN, TAPERED, PLAIN CRES, 6/0, 3/8 L MS26492-27 (96906)	EA	1	---	---	---	*	1	2	24	10	3	4	
N	P-	H-	1240-763-4685	ADAPTER, MICROMETER (RIVETED) 7634685 (19200)	EA	1	---	---	---	*	1	2	12	5	3	5	
C	P-	H-	5310-504-9929	WASHER, KEY 5049929 (19200)	EA	6	---	---	---	*	1	2	24	10	3	6	
N	X--		-----	RING 5049930 (19200)	----	1	---	---	---	---	---	---	---	---	3	7	
C	P-	F-	5305-282-7638	SETSCREW HDLS, FP, CRES, PSVT FNSH, NO. 1 72NF-2A, 1/16 L 540874 (21450)	EA	1	*	1	2	*	1	2	24	10	3	6	

ACT ON CODE	(1) SOURCE, MAINT, AND RECOV. CODE			(2) FEDERAL STOCK NO.	(3) DESCRIPTION Reference Number & Mfr Code Usable On Code	(4) UNIT OF MEAS	(5) QTY INC. IN UNIT	(6) 30-DAY DS MAINT. ALLOWANCE			(7) 30-DAY GS MAINT. ALLOWANCE			(8) 1YR. ALW PER 100 EQUIP. CNTGCV	(9) DEPOT MAINT. ALW PER 100 EQUIP.	(10) ILLUSTRATION	
	(A) SOURCE	(B) MAINT.	(C) RECOV.					(A) 1-20	(B) 21-50	(C) 51-100	(A) 1-20	(B) 21-50	(C) 51-100			(A) FIG. NO.	(B) ITEM NO.
N	P-	F-		5340-278-5325	PLUG 5039406 (19200)	EA	1	*	1	2	*	1	2	24	10	3	9
C	P-	F-		5340-597-2101	SPRING, HELICAL COMPRESSION MUW, 0.022 DIA STK, 0.18 OD, 0.405 OA, 5Y2 COIL 5045475 (00000)	EA	1	*	1	2	*	1	2	24	10	3	10
N	P-	F-		3120-080-9562	V-BEARING (SPRING LOADED) 0.2498 DIA, 0.20 W MS36689-1 (96906)	EA	1	*	1	2	*	1	2	24	10	3	11
N	P-	H-		5305-059-2483	SCREW, MACHINE HEX SKT, 3YDP, ALY STL, CD PL, NO. 2 64UNF-3A, 1/4 L MS51976-2 (96906)	EA	1	----	----	----	*	1	2	24	10	3	12
C	P-	H-		5305-206-5799	SETSCREW HDLS, SLTD, CRES, NO. 2 64NF-2A, 0.16 L 5034658 (00000)	EA	1	----	----	----	*	1	2	24	10	3	12
C	P-	H-		1290-513-2037	CAP, BALL 7687246 (19200)	EA	1	----	----	----	*	1	2	24	10	3	14
C	P-	H-		1240-613-8170	WORM ----- 6138170 (19200)	EA	1	----	----	----	*	1	2	24	10	3	15

C	P-	H-	1290-513-2055	SOCKET 7687244 (19200)	EA	1	-----	-----	-----	*	1	2	24	10	3	16
N	P-	F-	5305-728-1498	SCREW, MACHINE FL CSKH, CROSS REC, CRES, PVST FNSH, NO. 2 64UNF-2A, 5/16 L MS51960-9 (96906)	EA	6	*	1	2	*	1	2	24	10	3	17
N	X--		-----	FRAME 6138152 (19200)	-----	1	-----	-----	-----	-----	-----	-----	-----	-----	3	18
C	P-	F-	5330-527-8902	GASKET RBR, 1.30 W, 1.86 L, 0.45 THK 7687278 (19200)	EA	1	*	1	2	*	1	2	24	10	3	19
C	P-	F-	1240-599-9215	WINDOW 5049912 (19200)	EA	1	*	1	2	*	1	2	24	10	3	20

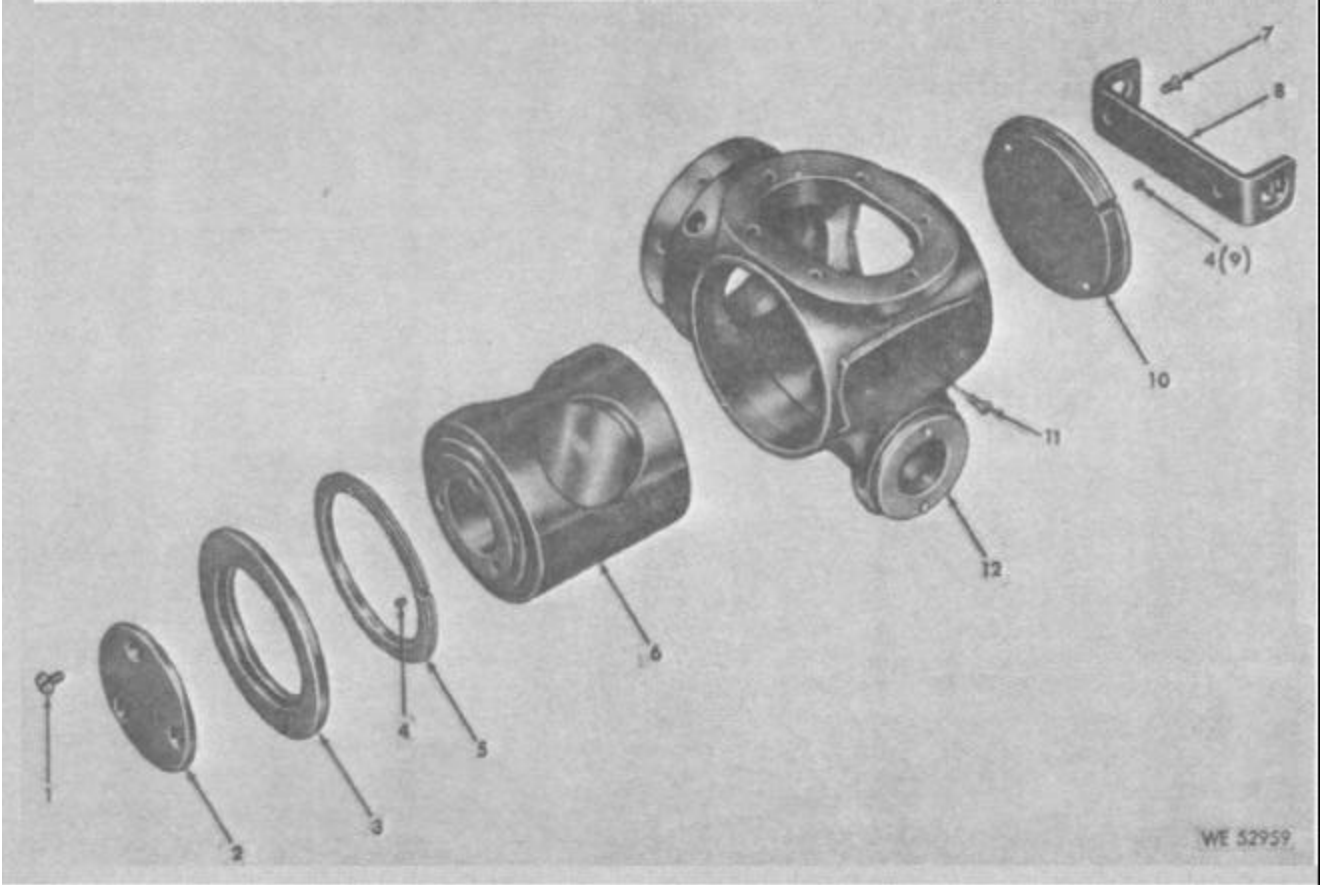

Figure 4. Head assembly 7687277-partial exploded view.

ACT ON CODE	(1) SOURCE, MAINT, AND RECOV. CODE			(2) FEDERAL STOCK NO.	(3) DESCRIPTION Reference Number & Mfr Code Usable On Code	(4) UNIT OF MEAS	(5) QTY INC. IN UNIT	(6) 30-DAY DS MAINT. ALLOWANCE			(7) 30-DAY GS MAINT. ALLOWANCE			(8) 1YR. ALW PER 100 EQUIP. CNTGCTY	(9) DEPOT MAINT. ALW PER 100 EQUIP.	(10) ILLUSTRATION	
	(A) SOURCE	(B) MAINT.	(C) RECOV.					(A) 1-20	(B) 21-50	(C) 51-100	(A) 1-20	(B) 21-50	(C) 51-100			(A) FIG. NO.	(B) ITEM NO.
					HEAD ASSEMBLY 7687277												
N	P-	H-		5303-701-5230	SCREW, MACHINE MS51960-8 (96906)	EA	1	----	----	----	REF	REF	REF	----	REF	4	1
N	P-	H-		1240-504-9932	PLATE 5049932 (19200)	EA	1	----	----	----	*	1	1	12	5	4	2
N	X--			-----	RING 5049933 (19200)		1	----	----	----	----	----	----	----	----	4	3
C	P-	F-		5305-282-7638	SETSCREW 540874 (21450)	EA	2	REF	REF	REF	REF	REF	REF		REF	4	4
N	X--			-----	RING 5048598 (19200)		1	----	----	----	----	----	----	----	----	4	5
N	X--			-----	HOLDER, PRISM ASSEMBLY 7669744 (19200)		1	----	----	----	----	----	----	----	----	4	6
N	P-	F-		5305-774-9704	SCREW, MACHINE MS51960-7 (96906)	EA	2	REF	REF	REF	REF	REF	REF	----	REF	4	7
C	P-	F-		1240-504-8599	SIGHT, OPEN 5048599 (19200)	EA	1	*	1	2	*	1	2	24	10	4	8
N	X--			-----	COVER 5048600 (19200)		1									4	10

ACT ON CODE	(1) SOURCE, MAINT, AND RECOV. CODE			(2) FEDERAL STOCK NO.	(3) DESCRIPTION Reference Number & Mfr Code Usable On Code	(4) UNIT OF MEAS	(5) QTY INC. IN UNIT	(6) 30-DAY DS MAINT. ALLOWANCE			(7) 30-DAY GS MAINT. ALLOWANCE			(8) 1YR. ALW PER 100 EQUIP. CNTGCTY	(9) DEPOT MAINT. ALW PER 100 EQUIP.	(10) ILLUSTRATION	
	(A) SOURCE	(B) MAINT.	(C) RECOV.					(A) 1-20	(B) 21-50	(C) 51-100	(A) 1-20	(B) 21-50	(C) 51-100			(A) FIG. NO.	(B) ITEM NO.
	N	P-	F-						5305-857-5190	SCREW, SELF SEALING 8624877 (19200)	EA	1	*			1	2
N	X--			-----	HEAD, ROTATING (PRESS) 7687296 (19200)		1	-----	-----	-----	-----	-----	-----	-----	-----	4	12

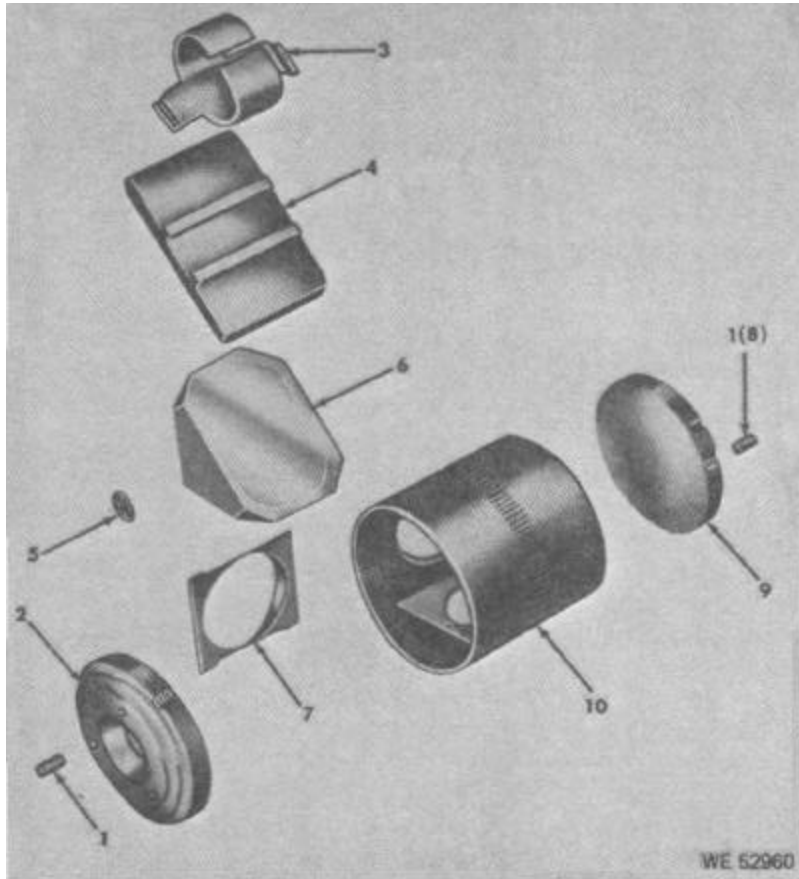

Figure 5. Holder assembly 7669744--exploded view.

ACT ON CODE	(1) SOURCE, MAINT, AND RECOV. CODE			(2) FEDERAL STOCK NO.	(3) DESCRIPTION Reference Number & Mfr Code Usable On Code	(4) UNIT OF MEAS	(5) QTY INC. IN UNIT	(6) 30-DAY DS MAINT. ALLOWANCE			(7) 30-DAY GS MAINT. ALLOWANCE			(8) 1YR. ALW PER 100 EQUIP. CNTGCTY	(9) DEPOT MAINT. ALW PER 100 EQUIP.	(10) ILLUSTRATION	
	(A) SOURCE	(B) MAINT.	(C) RECOV.					(A) 1-20	(B) 21-50	(C) 51-100	(A) 1-20	(B) 21-50	(C) 51-100			(A) FIG. NO.	(B) ITEM NO.
					HOLDER ASSEMBLY 7669744												
C	P-	H-		5305-282-7639	SETSCREW HDLS, FP, CRES, PSVT FNSH, NO. 1 72NF-2A, 1/16 L 540875 (21450)	EA	2	----	----	----	*	1	2	24	10	5	1
N	X--			-----	COVER 5049935 (19200)	----	1	----	----	----	----	----	----	----	----	5	2
C	P-	H-		5340-504-5418	SPRING, PRISM 5045418 (19200)	EA	1				*	1	1	12	5	5	3
N	X--			-----	SUPPORT PRISM (BACK) 5045419 (19200)	----	1	----	----	----	----	----	----	----	----	5	4
C	P-	H-		1240-503-2820	PAD, CUSHIONING CK 5032820 (19200)	EA	2	----	----	----	*	1	2	24	10	5	5
C	P-	H-		1240-601-6463	PRISM 90 DEGREES 6016463 (19200)	EA	1	----	----	----	*	1	2	24	10	5	6
N	X--			-----	SUPPORT, PRISM 5045490 (19200)	----	2	----	----	----	----	----	----	----	----	5	7

ACT ON CODE	(1) SOURCE, MAINT, AND RECOV. CODE			(2) FEDERAL STOCK NO.	(3) DESCRIPTION Reference Number & Mfr Code Usable On Code	(4) UNIT OF MEAS	(5) QTY INC. IN UNIT	(6) 30-DAY DS MAINT. ALLOWANCE			(7) 30-DAY GS MAINT. ALLOWANCE			(8) 1YR. ALW PER 100 EQUIP. CNTGCTY	(9) DEPOT MAINT. ALW PER 100 EQUIP.	(10) ILLUSTRATION	
	(A) SOURCE	(B) MAINT.	(C) RECOV.					(A) 1-20	(B) 21-50	(C) 51-100	(A) 1-20	(B) 21-50	(C) 51-100			(A) FIG. NO.	(B) ITEM NO.
	N	X--							COVER 6049934 (19200)	----	1	----	----			----	----
C	P-	H-		1240-763-4723	HOLDER (PINNED) 7634723 (19200)	EA	1	----	----	----	*	1	2	12	5	5	10

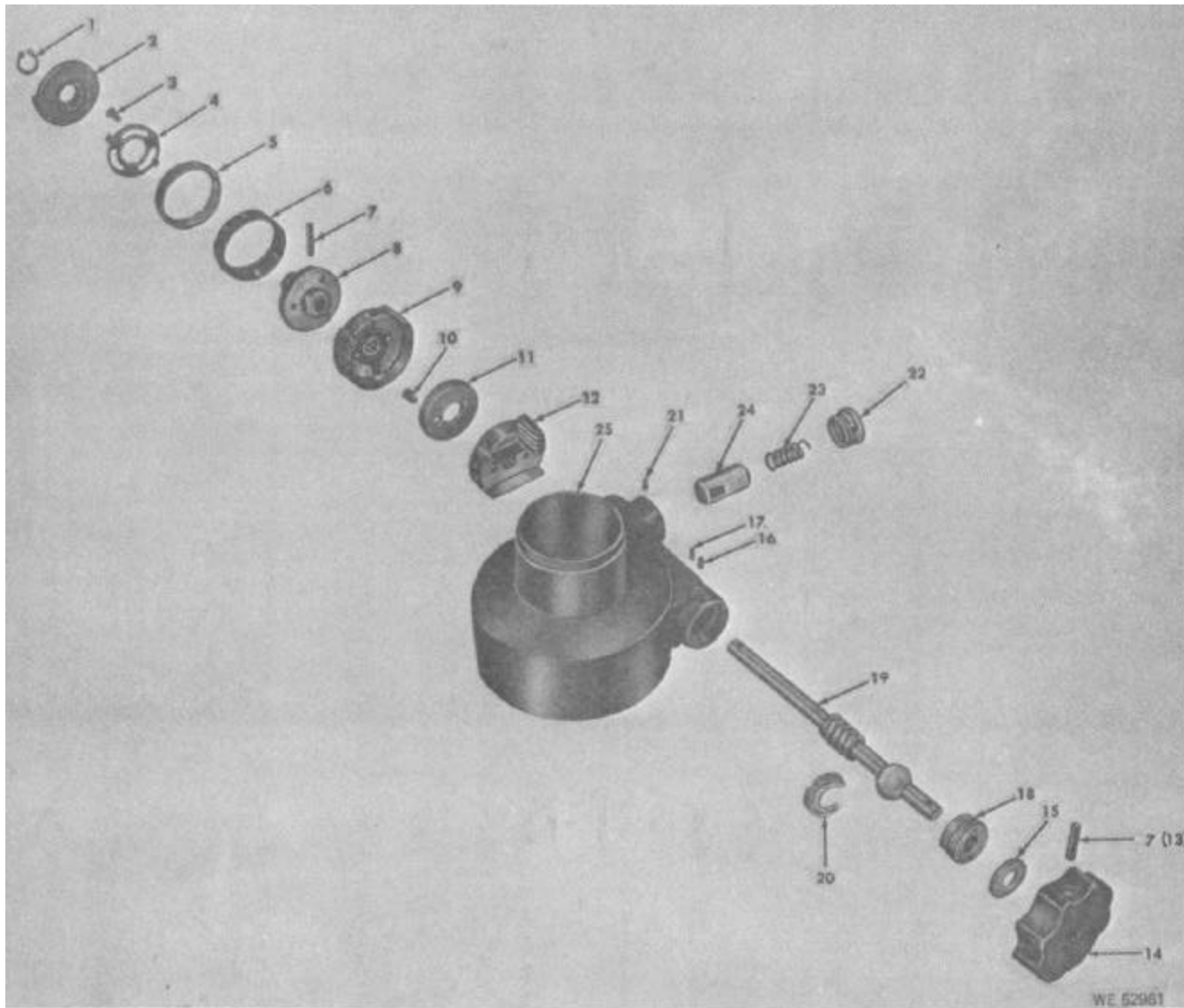

Figure 6. Housing assembly 7687285-exploded view.

ACT ON CODE	(1) SOURCE, MAINT, AND RECOV. CODE			(2) FEDERAL STOCK NO.	(3) DESCRIPTION Reference Number & Mfr Code Usable On Code	(4) UNIT OF MEAS	(5) QTY INC. IN UNIT	(6) 30-DAY DS MAINT. ALLOWANCE			(7) 30-DAY GS MAINT. ALLOWANCE			(8) 1YR. ALW PER 100 EQUIP. CNTGCTY	(9) DEPOT MAINT. ALW PER 100 EQUIP.	(10) ILLUSTRATION	
	(A) SOURCE	(B) MAINT.	(C) RECOV.					(A) 1-20	(B) 21-50	(C) 51-100	(A) 1-20	(B) 21-50	(C) 51-100			(A) FIG. NO.	(B) ITEM NO.
C	P-	F-	5340-768-7288	KNOB 7687288 (19200)	EA	1	*	1	2	*	1	2	24	10	6	2	
N	P-	F-	5305-952-2207	SCREW, MACHINE PNH, STLD, CS, CD OR ZINC PLD, NO. 448NF-2A, 3/16 L MS35226-13 (96906)	EA	3	*	1	2	*	1	2	24	10	6	3	
N	P-	F-	5310-768-7294	KEY 7687294 (19200)	EA	1	*	1	1	*	1	1	12	5	6	4	
N	P-	F-	5355-768-7290	INDEX 7687290 (19200)	EA	1	*	1	1	*	1	1	12	5	6	5	
C	P-	F-	5355-504-9920	DIAL, SCALE 5049920 (19200)	EA	1	*	1	2	*	1	2	24	10	6	6	
N	P-	F-	5315-187-3254	PIN, TAPERED, PLAIN GRES, NO. 4/0, 1/2 L MS24692-78 (96906)	EA	2	*	1	2	*	1	2	24	10	6	7	
C	P-	H-	1240-768-7287	ADAPTER 7687287 (19200)	EA	1	----	----	----	*	1	1	12	5	6	8	

ACT ON CODE	(1) SOURCE, MAINT, AND RECOV. CODE			(2) FEDERAL STOCK NO.	(3) DESCRIPTION Reference Number & Mfr Code Usable On Code	(4) UNIT OF MEAS	(5) QTY INC. IN UNIT	(6) 30-DAY DS MAINT. ALLOWANCE			(7) 30-DAY GS MAINT. ALLOWANCE			(8) 1YR. ALW PER 100 EQUIP. CNTGCTY	(9) DEPOT MAINT. ALW PER 100 EQUIP.	(10) ILLUSTRATION	
	(A) SOURCE	(B) MAINT.	(C) RECOV.					(A) 1-20	(B) 21-50	(C) 51-100	(A) 1-20	(B) 21-50	(C) 51-100			(A) FIG. NO.	(B) ITEM NO.
C	P-	H-		1240-763-6177	INDEX, AZIMUTH MICROMETER (RVT) 7636177 (19200)	EA	1	----	----	----	*	1	1	12	6	6	9
C	P-	H-		5305-022-5414	SCREW, MACHINE FILH, CRES, PSVT FNSH, NO. 65 44NF-2A, 3/16 L 225414 (19200)	EA	2	----	----	----	*	1	2	24	10	6	10
C	P-	H-		1240-504-9925	RATCHET 5049925 (19200)	EA	1	----	----	----	*	1	2	24	10	6	11
C	P-	H-		1240-613-8144	SHOE, WORM 6138144 (19200)	EA	1	----	----	----	*	1	2	24	10	6	12
C	P-	F-		5340-768-7286	KNOB 7687286 (19200)	EA	1	*	1	2	*	1		24	10	6	14
C	P-	F-		5310-285-7419	WASHER, NONMETALLIC 1/4 ID, 9/16 OD, 3/32 5048144 (19200)	EA	1	*	1	2	*	1		24	10	6	15
N	P-	H-		6305-724-7876	SETSCREW HEX SKT, FP, ALY STL, CD PL, NO. 2 64UNF-3A, 1/16 L MS51966-7 (96906)	EA	1	----	----	----	*	1	2	24	10	6	16
C	P-	H-		5305-206-5799	SETSCREW 5034658 (19200)	EA	1	----	----	----	REF	REF	REF	----	REF	6	17

C	P-	H-	1240-513-2035	SEAT, BALL SOCKET 7631561 (19200)	EA	1				*	1	2	24	10	6	18
C	P-	H-	1240-613-8146	WORM 6138146 (19200)	EA	1				*	1	2	24	10	6	19
N	P-	H-	1290-513-2034	SOCKET 7631560 (19200)	EA	1				*	1	2	24	10	6	20
N	P-	F-	5305-716-8035	SETSCREW HEX SKT, CP, ALY STL, CD PL, NO. 2 64UNF-3A, 1/8 L MS51974-1 (96906)	EA	1	*	1	1	*	1	1	12	5	6	21
N	P-	F-	4730-278-5208	PLUG 5048595 (19200)	EA	1	*	1	1	*	1	1	12	5	6	22
C	P-	F-	5340-597-2051	SPRING, HELICAL COMPRESSION MUW, 0.041 DIA STK, 0.295 OD, 0.80 OA, 8 COIL 7584003 (19200)	EA	1	*	1	1	*	1	1	12	5	6	23
N	P-	H-	3120-896-15662	V-BEARING (SPRING LOADED THROW OUT TYPE), 0.250 DIA, 27/32 L MS35688-2 (96906)	EA	1				*	1	1	12	5	6	24
N	X--			HOUSING 6529394 (19200)		1									6	25

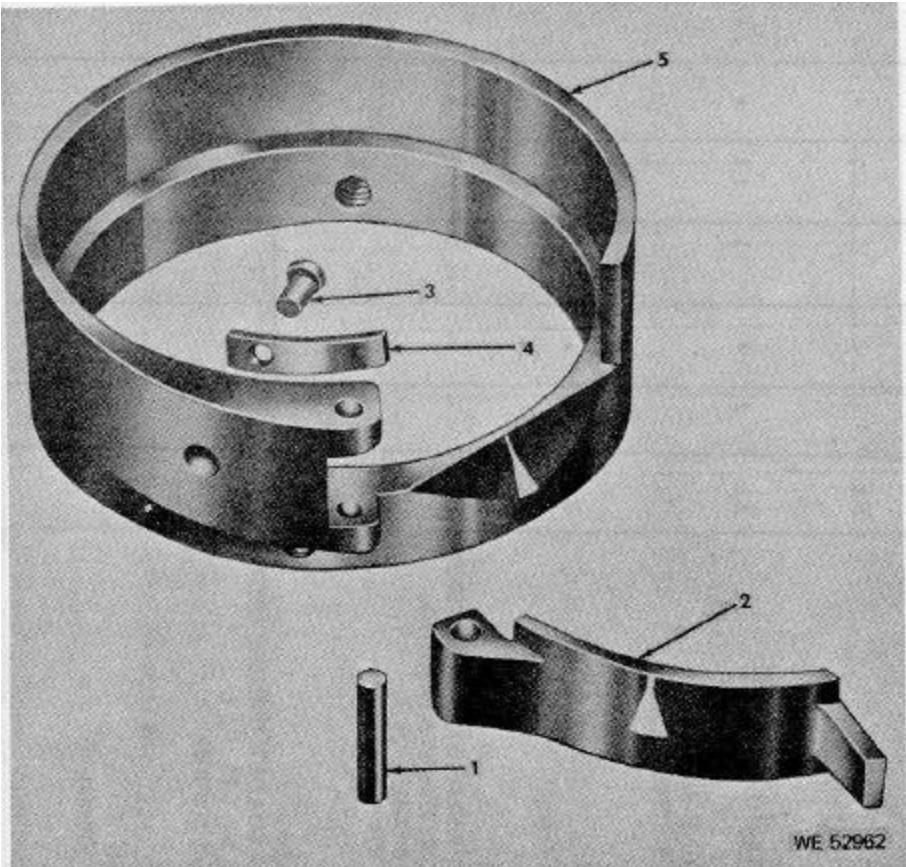

Figure 7. Collar assembly 7687280--exploded view.

ACT ON CODE	(1) SOURCE, MAINT, AND RECOV. CODE			(2) FEDERAL STOCK NO.	(3) DESCRIPTION Reference Number & Mfr Code Usable On Code	(4) UNIT OF MEAS	(5) QTY INC. IN UNIT	(6) 30-DAY DS MAINT. ALLOWANCE			(7) 30-DAY GS MAINT. ALLOWANCE			(8) 1YR. ALW PER 100 EQUIP. CNTGCTY	(9) DEPOT MAINT. ALW PER 100 EQUIP.	(10) ILLUSTRATION	
	(A) SOURCE	(B) MAINT.	(C) RECOV.					(A) 1-20	(B) 21-50	(C) 51-100	(A) 1-20	(B) 21-50	(C) 51-100			(A) FIG. NO.	(B) ITEM NO.
	N	X1--								COLLAR ASSEMBLY 7687280 PIN 505281 (21450)		1					
N	X1--				INDEX 7687298 (19200)		1									7	2
N	X1--				RIVET MS20615-3CU4 (96906)		1									7	3
C	X1--				SPRING PH BRZ, 0.275 W, 0.75 L, 0.020 THK 7687293 (19200)		1									7	4
N	X1--				COLLAR (RVT) 7687281 (19200)		1									7	5

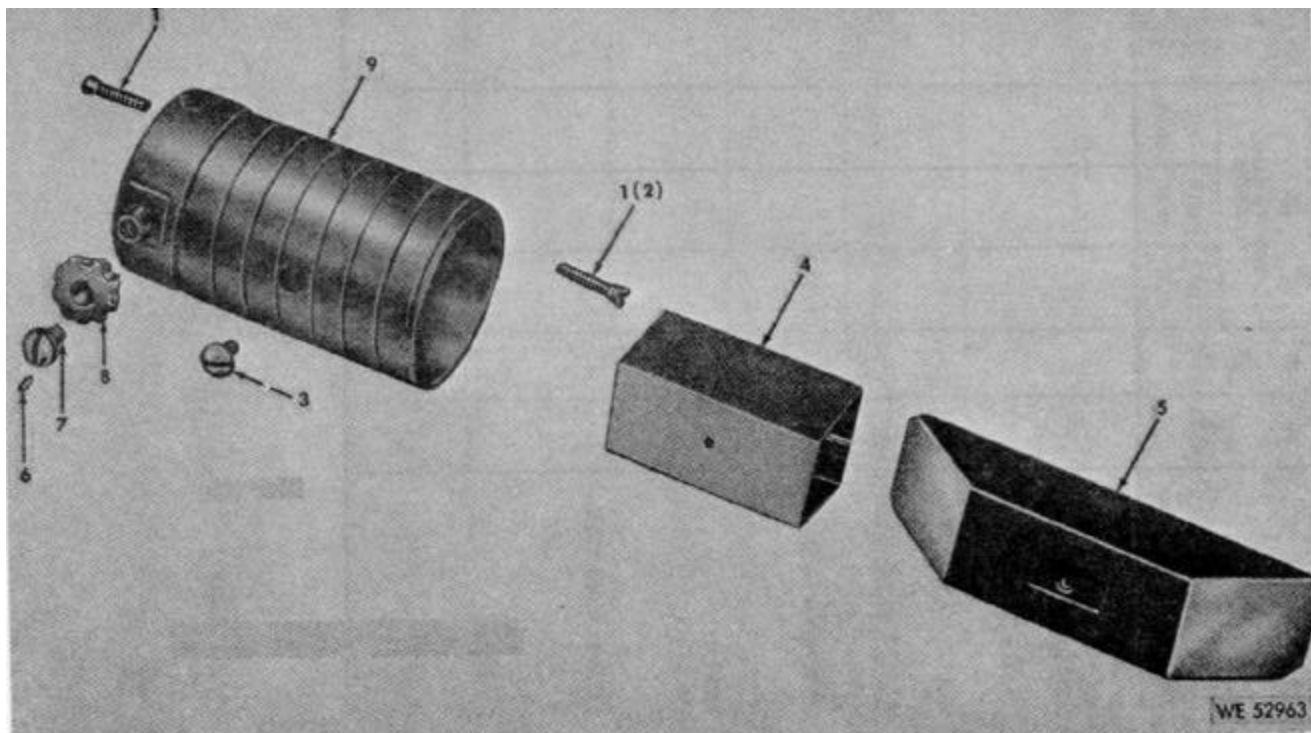

Figure 8. Sleeve assembly 7635802-exploded view.

ACT ON CODE	(1) SOURCE, MAINT, AND RECOV. CODE			(2) FEDERAL STOCK NO.	(3) DESCRIPTION Reference Number & Mfr Code Usable On Code	(4) UNIT OF MEAS	(5) QTY INC. IN UNIT	(6) 30-DAY DS MAINT. ALLOWANCE			(7) 30-DAY GS MAINT. ALLOWANCE			(8) 1YR. ALW PER 100 EQUIP. CNTGCV	(9) DEPOT MAINT. ALW PER 100 EQUIP.	(10) ILLUSTRATION	
	(A) SOURCE	(B) MAINT.	(C) RECOV.					(A) 1-20	(B) 21-50	(C) 51-100	(A) 1-20	(B) 21-50	(C) 51-100			(A) FIG. NO.	(B) ITEM NO.
	PRISM, OPTICAL INSTRUMENT 7635302																
C	P-	H-		5305-531-9552	SCREW, EXTERNALLY RELIEVED BODY FLH, CRES, NO. 3 56NF-4A, 27/64 L 5179606 (19200)	EA	8				*	1	2	24	10	8	1
C	P-	H-		5305-282-8921	SCREW FLH, CRES, PSVT FNSH, NO. 8 36NS-3, 0.167 L 5048586 (19200)	EA	1				*	1	1	12	5	8	3
C	P-	H-		1240-504-9946	SHIELD, PRISM BLK, PPR, 1 9/16 W, 2 13/16 L, 0.005 THK 5049946 (19200)	EA	1				*	1	2	24	10	8	4
C	P-	H-		1240-763-5304	PRISM, OPTICAL INSTRUMENT 7635304 (19200)	EA	1				*	1	1	12	5	8	5
N	X1--				SCREW 540876 (10001)		1									8	6
N	P-	H-		5305-206-1043	SCREW, SPECIAL 5030880 (19200)	EA	1				*	1	1	12	5	8	7
N	X1--				PINION 6138141 (19200)		1									8	8
N	X1--				HOLDER, PRISM 6179894 (19200)		1									8	9

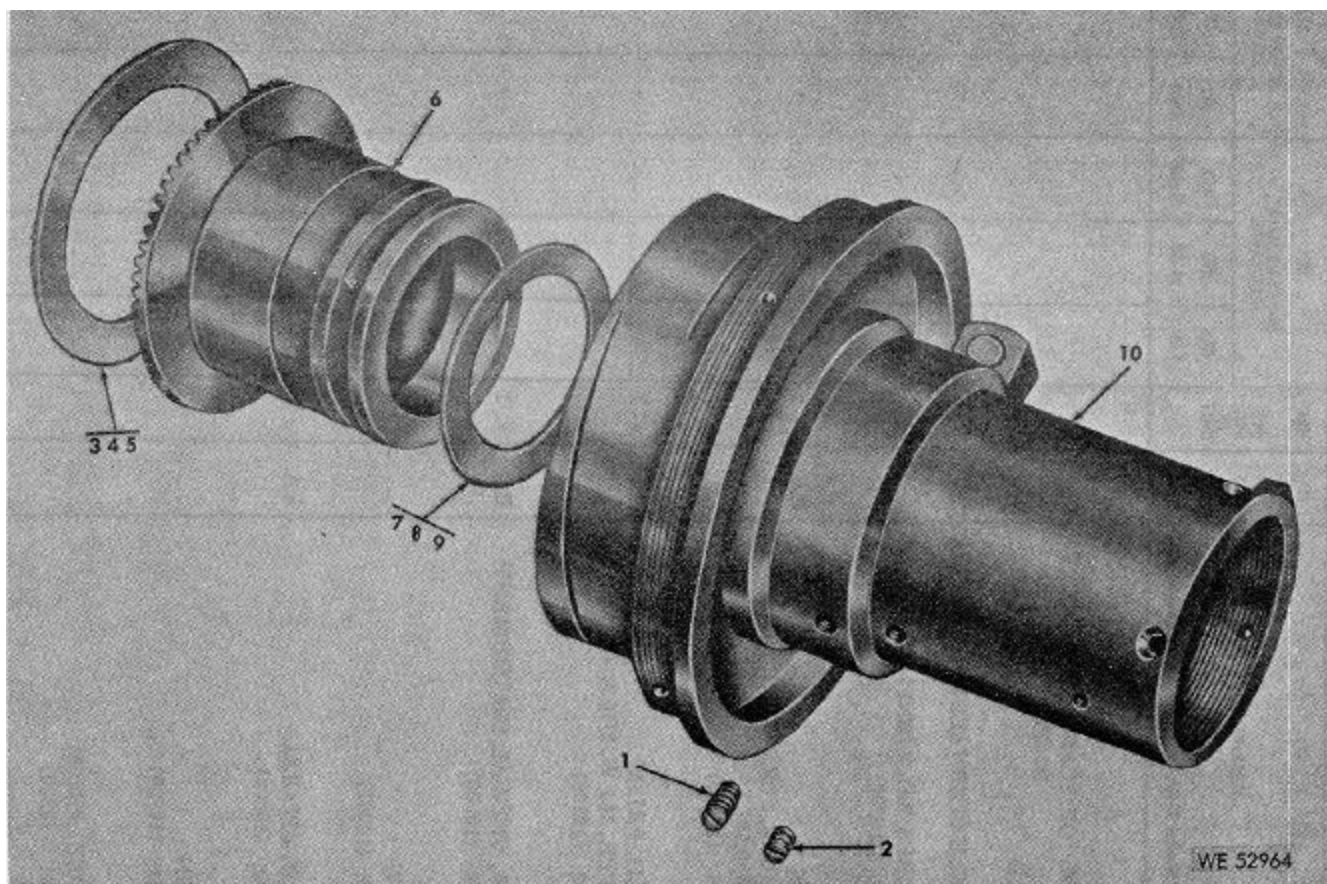

Figure 9. Shank assembly 7635502--exploded view.

ACT ON CODE	(1) SOURCE, MAINT, AND RECOV. CODE			(2) FEDERAL STOCK NO.	(3) DESCRIPTION Reference Number & Mfr Code Usable On Code	(4) UNIT OF MEAS	(5) QTY INC. IN UNIT	(6) 30-DAY DS MAINT. ALLOWANCE			(7) 30-DAY GS MAINT. ALLOWANCE			(8) 1YR. ALW PER 100 EQUIP. CNTGCV	(9) DEPOT MAINT. ALW PER 100 EQUIP.	(10) ILLUSTRATION	
	(A) SOURCE	(B) MAINT.	(C) RECOV.					(A) 1-20	(B) 21-50	(C) 51-100	(A) 1-20	(B) 21-50	(C) 51-100			(A) FIG. NO.	(B) ITEM NO.
	SHANK ASSEMBLY 7636577																
C	P-	H-	5305-207-4405	SETSCREW HDLS, SLTD, CRES, PHOS FNSH, NO. 10 40NS-3A, 0.075 L 5315414 (19200)	EA	2				*	1	1	12	5	9	1	
C	P-	H-	5805-207-4404	SETSCREW HDLS, SLTD, CRES, PHOS FNSH, NO. 10 40NS-3A, 0.16 L 5315415 (19200)	EA	1				*	1	1	12	5	9	2	
N	P-	H-	5365-182-9819	SHIM, STEEL (.004 THK) 10556748-1 (19200)	EA	V				*	1	1	12	5	9	3	
N	P-	H-	5365-182-9820	SHIM, STEEL (.005 THK) 10556748-2 (19200)	EA	V				*	1	1	12	5	9	4	
N	P-	H-	5365-182-9823	SHIM, STEEL (.006 THK) 10556748-3 (19200)	EA	V				*	1	1	12	5	9	6	
N	X- -			GEAR 6138142 (19200)		1									9	6	
N	P-	H-	5365-182-9824	SHIM, STEEL (.004 THK) 10556749-1 (19200)	EA	V				*	1	1	12	5	9	7	

ACT ON CODE	(1) SOURCE, MAINT, AND RECOV. CODE			(2) FEDERAL STOCK NO.	(3) DESCRIPTION Reference Number & Mfr Code Usable On Code	(4) UNIT OF MEAS	(5) QTY INC. IN UNIT	(6) 30-DAY DS MAINT. ALLOWANCE			(7) 30-DAY GS MAINT. ALLOWANCE			(8) 1YR. ALW PER 100 EQUIP. CNTGCTY	(9) DEPOT MAINT. ALW PER 100 EQUIP.	(10) ILLUSTRATION	
	(A) SOURCE	(B) MAINT.	(C) RECOV.					(A) 1-20	(B) 21-50	(C) 51-100	(A) 1-20	(B) 21-50	(C) 51-100			(A) FIG. NO.	(B) ITEM NO.
	N	P-	H-						6365-182-9825	SHIM, STEEL (.005 THK) 10556749-2 (19200)	EA	V					
N	P-	H-		5866-182-9826	SHIM, STEEL (.006 THK) 10556749-3 (19200)	EA	V				*	1	1	12	6	9	9
N	X-	-			SHANK (BRAZED) 5681972 (19200)		1									9	10

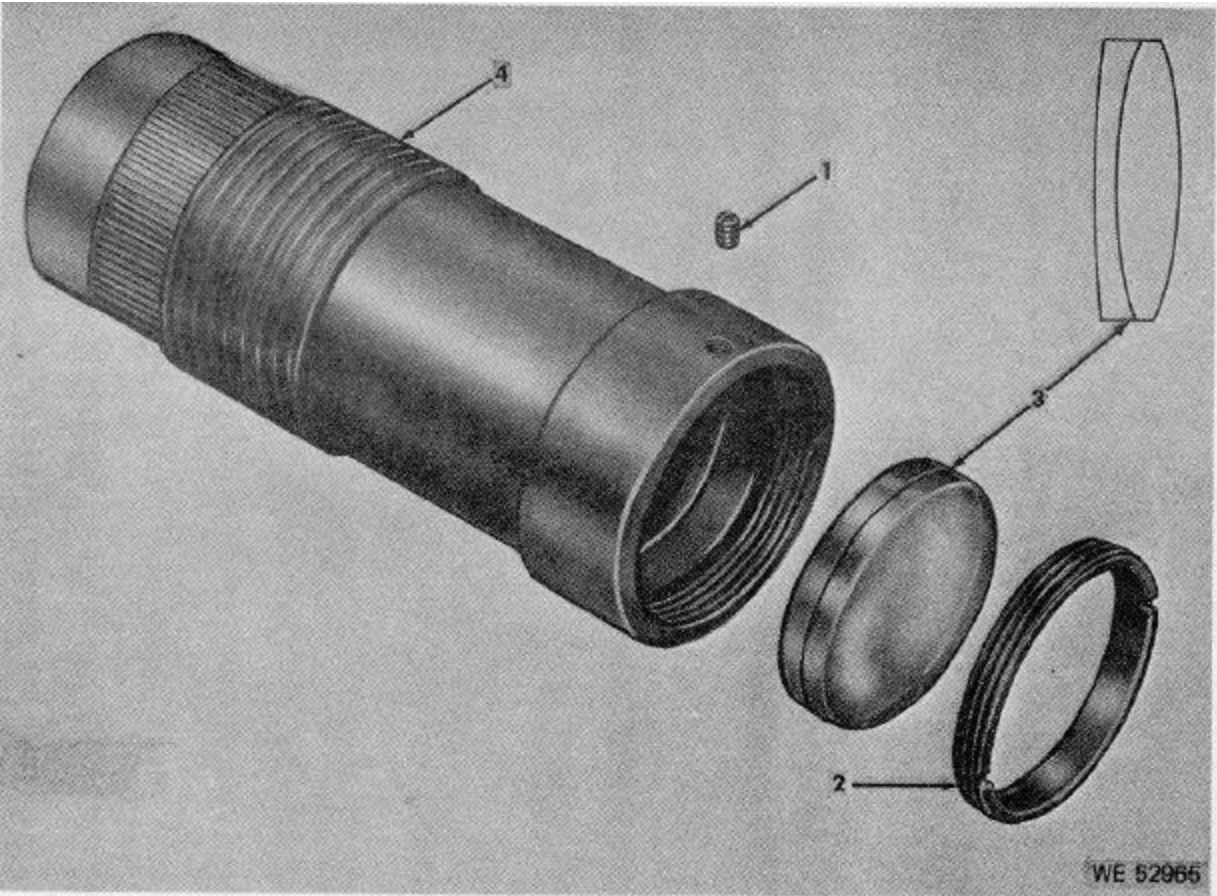

Figure 10. Objective assembly 7635305-exploded view.

ACT ON CODE	(1) SOURCE, MAINT, AND RECOV. CODE			(2) FEDERAL STOCK NO.	(3) DESCRIPTION Reference Number & Mfr Code Usable On Code	(4) UNIT OF MEAS	(5) QTY INC. IN UNIT	(6) 30-DAY DS MAINT. ALLOWANCE			(7) 30-DAY GS MAINT. ALLOWANCE			(8) 1YR. ALW PER 100 EQUIP. CNTGCV	(9) DEPOT MAINT. ALW PER 100 EQUIP.	(10) ILLUSTRATION	
	(A) SOURCE	(B) MAINT.	(C) RECOV.					(A) 1-20	(B) 21-50	(C) 51-100	(A) 1-20	(B) 21-50	(C) 51-100			(A) FIG. NO.	(B) ITEM NO.
C	P-	H-		6505-282-7659	SETSCREW HDLS, CP, CRES, PSVT FNSH, NO. 1 72UNF-2A, 2/32 L 540963 (21450)	EA	1				*	1	2	24	10	10	1
C	P-	H-		5340-286-7903	RING, EXTERNALLY THREADED BRS, 3/4 36NS-3 OD, 0.12 THK 5048590 (19200)	EA	1				*	1	2	24	10	10	2
C	P-	H-		1240-604-9913	LENS, OPTICAL INSTRUMENT 6049913 (19200)	EA	1				*	1	2	24	10	10	3
C	P-	H-		1240413-8149	CELL, OPTICAL ELEMENT BRS, 13/16-36NS-3 OD, 2 1/8 OA 6138149 (19200)	EA	1				*	1	1	12	5	10	4

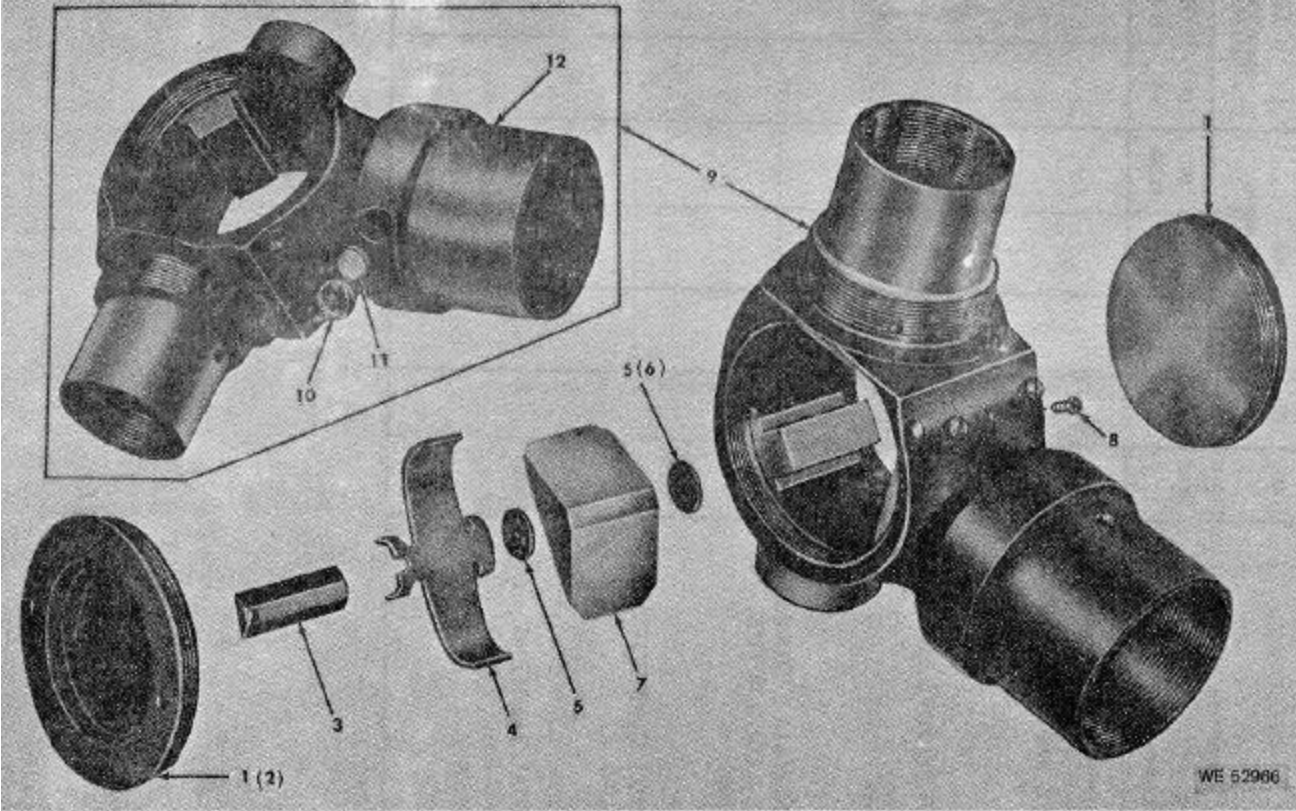

Figure 11. Elbow assembly 7199579-exploded view.

ACT ON CODE	(1) SOURCE, MAINT, AND RECOV. CODE			(2) FEDERAL STOCK NO.	(3) DESCRIPTION Reference Number & Mfr Code Usable On Code	(4) UNIT OF MEAS	(5) QTY INC. IN UNIT	(6) 30-DAY DS MAINT. ALLOWANCE			(7) 30-DAY GS MAINT. ALLOWANCE			(8) 1YR. ALW PER 100 EQUIP. CNTGCV	(9) DEPOT MAINT. ALW PER 100 EQUIP.	(10) ILLUSTRATION	
	(A) SOURCE	(B) MAINT.	(C) RECOV.					(A) 1-20	(B) 21-50	(C) 51-100	(A) 1-20	(B) 21-50	(C) 51-100			(A) FIG. NO.	(B) ITEM NO.
					ELBOW ASSEMBLY 7199579												
N	X	-			COVER 5048602 (19200)		2									11	1
C	P	H		5340-503-7821	CLIP, SPRING TENSION BRS, 0.27 W, 0.70 L, 0.091 THK 5037821 (19200)	EA	1				1	2	24	10		11	3
N	P	H		1240-492-6071	HOLDER ASSEMBLY 106555982 (19200)	EA	1				1	1	12	5		11	4
C	P	H		1240-503-2820	PAD, CUSHIONING 5032820 (19200)	EA	2				REF	REF	REF	REF		11	5
C	P	H		1240-503-6234	PRISM, OPTICAL INSTRUMENT 5036234 (19200)	EA	1				*	1	2	24	10	11	7
N	P	F		5305-857-5190	SCREW, SELF SEALING 8624877 (19200)	EA	1	REF	REF	REF	REF	REF	REF	REF		11	8
C	X	-			ELBOW (PRESSED) 7199972 (19200)		1									11	9
N	P	F		6650-492-6072	RING 8624881 (19200)	EA	1	*	1	2	*	1	2	24	10	11	10

ACT ON CODE	(1) SOURCE, MAINT, AND RECOV. CODE			(2) FEDERAL STOCK NO.	(3) DESCRIPTION Reference Number & Mfr Code Usable On Code	(4) UNIT OF MEAS	(5) QTY INC. IN UNIT	(6) 30-DAY DS MAINT. ALLOWANCE			(7) 30-DAY GS MAINT. ALLOWANCE			(8) 1YR. ALW PER 100 EQUIP. CNTGCTY	(9) DEPOT MAINT. ALW PER 100 EQUIP.	(10) ILLUSTRATION	
	(A) SOURCE	(B) MAINT.	(C) RECOV.					(A) 1-20	(B) 21-50	(C) 51-100	(A) 1-20	(B) 21-50	(C) 51-100			(A) FIG. NO.	(B) ITEM NO.
	C	P-	F-						1290-617-8192	WINDOW, OPTICAL INSTRUMENT 5178192 (19200)	EA	1	*			1	2
N	X-	-			ELBOW 6529396 (19200)		1									11	12

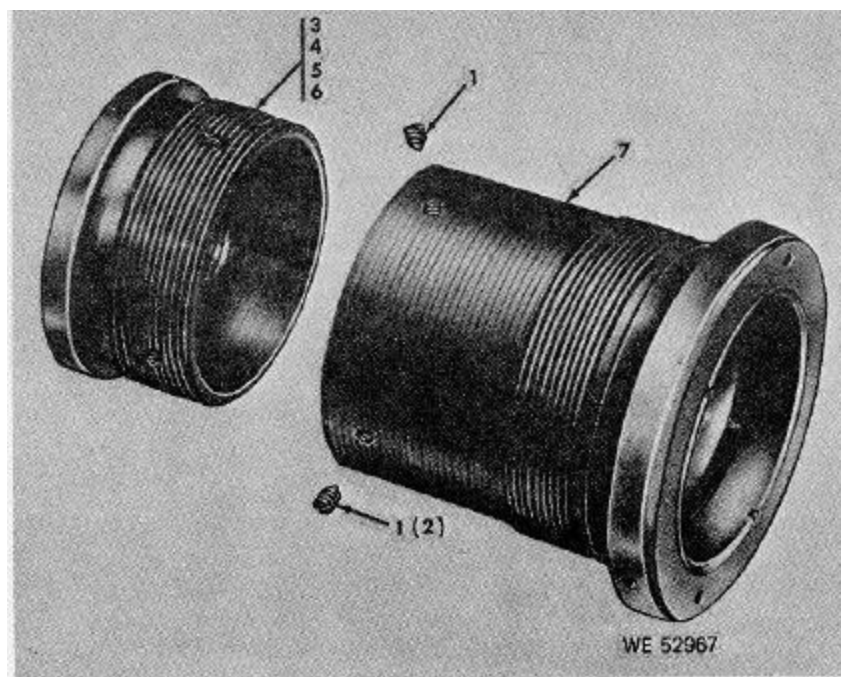

Figure 12. Eyepiece assembly 7687266 (M12A7C and M12A7K), 8248176 (M12A7H), 8570118 (M12A7Q), and 8289215 (M12A7S) --partial exploded view.

ACT ON CODE	(1) SOURCE, MAINT, AND RECOV. CODE			(2) FEDERAL STOCK NO.	(3) DESCRIPTION Reference Number & Mfr Code Usable On Code	(4) UNIT OF MEAS	(5) QTY INC. IN UNIT	(6) 30-DAY DS MAINT. ALLOWANCE			(7) 30-DAY GS MAINT. ALLOWANCE			(8) 1 YR. ALW PER 100 EQUIP. CNTGCV	(9) DEPOT MAINT. ALW PER 100 EQUIP.	(10) ILLUSTRATION		
	(A) SOURCE	(B) MAINT.	(C) RECOV.					(A) 1-20	(B) 21-50	(C) 51-100	(A) 1-20	(B) 21-50	(C) 51-100			(A) FIG. NO.	(B) ITEM NO.	
C	P-	H-		5305-282-7659	EYEPIECE ASSEMBLY M12A7C, M12A7K-7687266 M12A7H-8243176 M12A7Q-8570118 M12A7S-8289215 SETSCREW 5409.63 (21450)	EA	2				REF	REF	REF		REF	12	1	
N	A--	-			CELL ASSEMBLY, RETICLE 7647628 (19200)		1										12	3
N	A--				CELL ASSEMBLY, RETICLE 8243175 (19200)		1										12	4
N	A--				CELL ASSEMBLY, RETICLE 8570119 (19200)		1										12	5
N	A--				CELL ASSEMBLY, RETICLE 8289214 (19200)		1										12	6
N	X--				CELL ASSEMBLY, EYELENS 7687265 (19200)		1										12	7

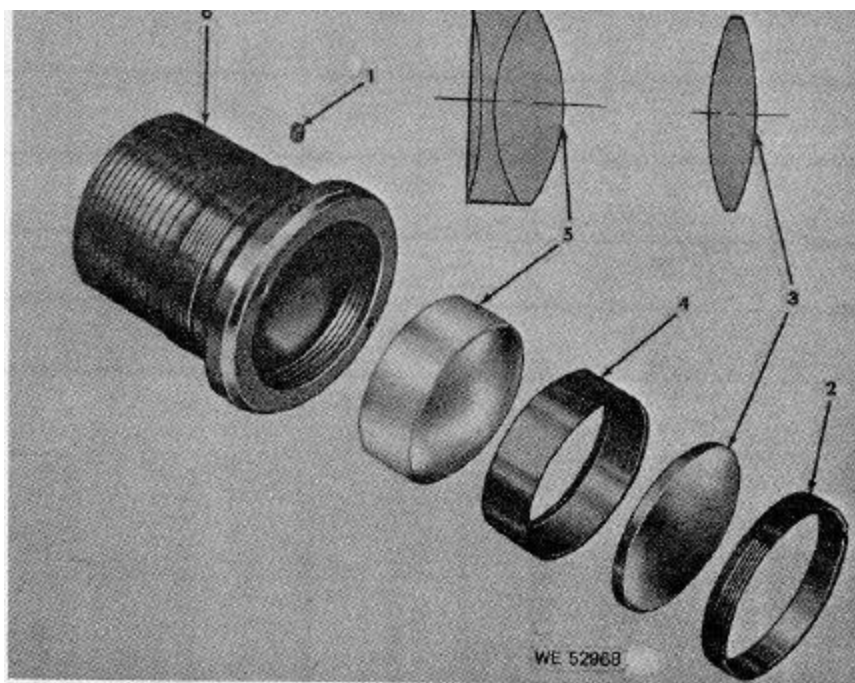

Figure 13. Cell, eyepiece assembly 7687265 (M12A7K) -exploded view.

ACT ON CODE	(1) SOURCE, MAINT, AND RECOV. CODE			(2) FEDERAL STOCK NO.	(3) DESCRIPTION Reference Number & Mfr Code Usable On Code	(4) UNIT OF MEAS	(5) QTY INC. IN UNIT	(6) 30-DAY DS MAINT. ALLOWANCE			(7) 30-DAY GS MAINT. ALLOWANCE			(8) 1YR. ALW PER 100 EQUIP. CNTGCV	(9) DEPOT MAINT. ALW PER 100 EQUIP.	(10) ILLUSTRATION		
	(A) SOURCE	(B) MAINT.	(C) RECOV.					(A) 1-20	(B) 21-50	(C) 51-100	(A) 1-20	(B) 21-50	(C) 51-100			(A) FIG. NO.	(B) ITEM NO.	
					CELL, EYELENS ASSEMBLY 7687265													
C	P-	H-		5305-282-7639	SETSCREW 540875 (21450)	EA	1				REF	REF	REF		REF	13	1	
C	P-	H-		5340-597-8830	RING, EXTERNALLY THREADED BRS, 1.03-36NS-3 OD, 0.23 THK 5049917 (19200)	EA	1				*	1	1	12	5	13	2	
C	P-	H-		1240-504-9914	LENS, OPTICAL INSTRUMENT GL, 0.999 DIA, 0.281 AXIAL THK, 0.062 ET 5049914 (19200)	EA	1				*	1	2	24	10	13	3	
N	X-	-			SEPARATOR 7687264 (19200)		1									13	4	
C	P-	H-		1240-504-9915	LENS, OPTICAL INSTRUMENT GL, 0.999 DIA, 0.508 AXIAL THK, 0.359 ET 5049915 (19200)	EA	1				*	1	1	12	5	13	5	
C	P-	H-		1240-613-8150	CELL, OPTICAL ELEMENT 6138150 (19200)	EA	1				*	1	1	12	5	13	6	

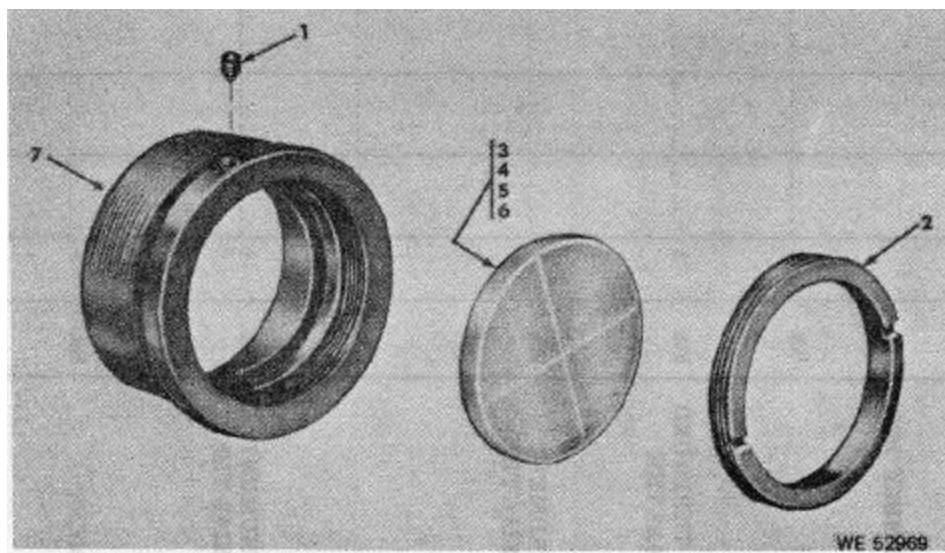

Figure 14. Cell reticle assembly 7647628 (M12A7C), 8243175 (M12A7H), 8570119 (M12A7Q), 8289214 (M12A7S) -exploded view.

ACT ON CODE	(1) SOURCE, MAINT, AND RECOV. CODE			(2) FEDERAL STOCK NO.	(3) DESCRIPTION Reference Number & Mfr Code Usable On Code	(4) UNIT OF MEAS	(5) QTY INC. IN UNIT	(6) 30-DAY DS MAINT. ALLOWANCE			(7) 30-DAY GS MAINT. ALLOWANCE			(8) 1YR. ALW PER 100 EQUIP. CNTGCV	(9) DEPOT MAINT. ALW PER 100 EQUIP.	(10) ILLUSTRATION		
	(A) SOURCE	(B) MAINT.	(C) RECOV.					(A) 1-20	(B) 21-50	(C) 51-100	(A) 1-20	(B) 21-50	(C) 51-100			(A) FIG. NO.	(B) ITEM NO.	
					CELL RETICLE ASSEMBLY - 7647628 8243175 8570119 8289214													
C	P-	H-		5305-282-7639	SETSCREW 540875 (21450)	EA	1				REF	REF	REF		REF	14	1	
C	P-	H-		5340-285-7902	RING, EXTERNALLY THREADED BRS, 0.86-36NS-8 OD, 0.12 THK 5049918 (19200)	EA	1				*	1	1	12	5	14	2	
C	P-	H-		1240-613-8147	RETICLE, OPTICAL INSTRUMENT 6138147 (19200)	EA	1				*	1	2	24	10	14	3	
C	P-	H-		1240-300-7983	RETICLE, OPTICAL INSTRUMENT 8243174 (19200)	EA	1				*	1	2	24	10	14	4	
N	P-	H-		1240-947-3047	RETICLE, OPTICAL INSTRUMENT 8213746 (19200)	EA	1				*	1	2	24	10	14	5	
N	P-	H-		1240-918-4105	RETICLE, OPTICAL INSTRUMENT 8246009 (19200)	EA	1				*	1	2	24	10	14	6	
C	P-	H-		1240-613-8148	CELL BRS, 1 1/32-36NS-3 OD, 9/16 OA 6138148 (19200)	EA	1				*	1	1	12	5	14	7	

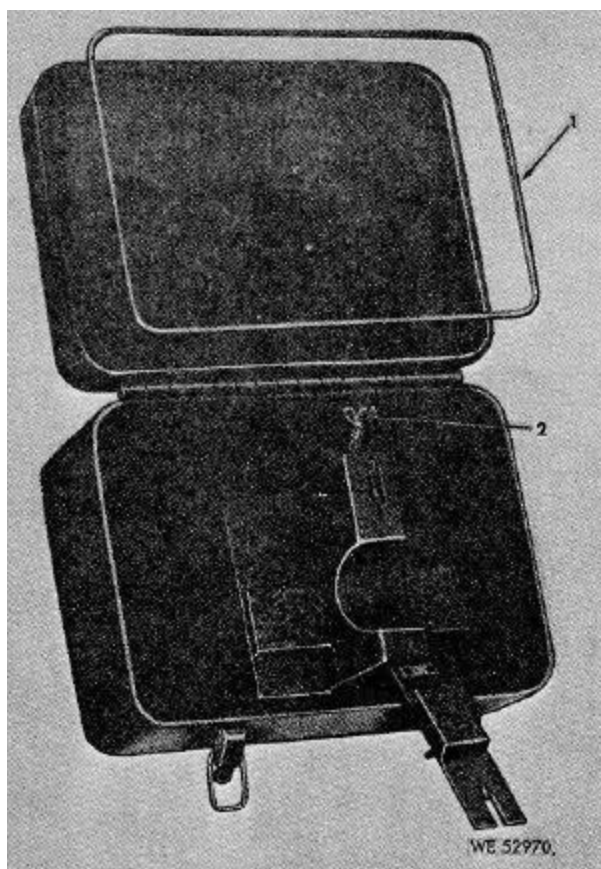

Figure 15. Chest, packing M27, 7691521-partial exploded view.

SECTION III. SPECIAL TOOLS, TEST AND SUPPORT EQUIPMENT FOR DIRECT DUPPORT, GENERAL SUPPORT AND DEPOT MAINTENANCE

ACT ON CODE	(1) SOURCE, MAINT, AND RECOV. CODE			(2) FEDERAL STOCK NO.	(3) DESCRIPTION Reference Number & Mfr Code Usable On Code	(4) UNIT OF MEAS	(5) QTY INC. IN UNIT	(6) 30-DAY DS MAINT. ALLOWANCE			(7) 30-DAY GS MAINT. ALLOWANCE			(8) 1YR. ALW PER 100 EQUIP. CNTGCV	(9) DEPOT MAINT. ALW PER 100 EQUIP.	(10) ILLUSTRATION	
	(A) SOURCE	(B) MAINT.	(C) RECOV.					(A) 1-20	(B) 21-50	(C) 51-100	(A) 1-20	(B) 21-50	(C) 51-100			(A) FIG. NO.	(B) ITEM NO.
	TOOLS AND EQUIPMENT EQUIPMENT																
C	P-	C-		1240-769-1521	CHEST, PACKING M27 7691521 (19200)	EA	*	1	2	*	1	2	24	10	15		
	REPAIR PARTS FOR EQUIPMENT																
C	P-	F-		5320-298-5124	GASKET RBR, 7 17/64 W, 10 49/64 L, 36 THK 7640310 (19200)	EA	1	*	1	2	*	1	2	24	10	15	1
N	P-	F-			NUT, WING 5185119 (19200)	EA	1	*	1	1	*	1	1	12	5	15	2

**SECTION IV. INDEX-FEDERAL STOCK NUMBER AND REFERENCE NUMBER
CROSS-REFERENCED TO FIGURE AND ITEM NUMBER**

Stock Number	Figure No.	Item No.	Stock Number	Figure No.	Item No.
1240-114-1081	2	7	5305-531-5230	2	28
1240-300-7983	14	4	5305-701-5230	4	1
1240-492-6071	11	4	5305-716-8035	6	21
1240-503-2820	5	5	5305-724-7276	2	11
1240-503-2820	11	5	5305-724-7876	6	16
1240-503-6234	11	7	5305-728-1498	3	17
1240-504-8599	4	8	5305-774-9704	2	2
1240-504-9913	10	3	5305-774-9704	4	7
1240-504-9914	13	3	5305-781-9479	2	1
1240-504-9915	13	5	5305-857-5190	4	11
1240-504-9925	6	11	5305-857-5190	11	8
1240-504-9932	4	2	5305-912-7656	3	1
1240-504-9940	2	32	5305-952-2207	6	3
1240-504-9946	8	4	5310-285-7419	6	15
1240-513-2035	6	18	5310-504-9929	3	6
1240-599-9215	3	20	5310-639-7660	2	20
1240-601-6463	5	6	5310-768-7294	6	4
1240-613-8144	6	12	5315-187-3226	3	4
1240-613-8146	6	19	5315-187-3254	6	7
1240-613-8147	14	3	5330-298-5124	15	1
1240-613-8148	14	7	5330-527-8902	3	19
1240-613-8149	10	4	5340-278-5325	3	9
1240-613-8150	13	6	5340-285-7902	14	2
1240-613-8170	3	15	5340-285-7903	10	2
1240-622-4405	2	21	5340-503-7821	11	8
1240-757-7823	2	27	5340-504-5418	5	3
1240-763-4685	3	5	5340-597-2051	6	23
1240-763-4723	5	10	5340-597-2101	3	10
1240-763-5304	8	5	5340-597-8830	13	2
1240-763-6177	6	9	5340-768-7286	6	14
1240-763-6238	2	16	5340-768-7288	6	2
1240-765-0547	2	23	5340-818-0872	6	1
1240-768-7280	2	12	5355-504-9920	6	6
1240-768-7287	6	8	5355-504-9926	3	3
1240-769-1521	15	—	5355-667-9382	3	2
1240-918-4105	14	6	5355-768-7290	6	5
1240-947-3047	14	5	5365-182-9811	2	17
1290-513-2034	6	20	5365-182-9812	2	18
1290-513-2037	3	14	5365-182-9813	2	19
1290-513-2055	3	16	5365-182-9814	2	22
1290-517-8192	11	11	5365-182-9815	2	24
3120-080-9562	3	11	5365-182-9817	2	25
3120-896-1552	6	24	5365-182-9818	2	26
4730-278-5308	6	22	5365-182-9819	9	8
5305-022-5414	6	10	5365-182-9820	9	4
5305-050-3944	2	5	5365-182-9823	9	5
5305-054-5635	1	1	5365-182-9824	9	7
5305-057-1631	2	29	5365-182-9825	9	8
5305-059-2483	3	12	5365-182-9826	9	9
6305-081-2651	2	31	6650-492-6072	11	10
5305-206-1043	8	7	9905-191-7213	1	2
5305-206-5799	3	13			
5305-206-5799	6	17			
5305-206-5799	6	17			
5305-207-4404	9	2			
5305-207-4405	9	1			
5305-282-7638	3	8			
5305-282-7638	4	4			
5305-282-7639	5	1			
5305-282-7639	13	1			
5305-282-7639	14	1			
5305-282-7659	10	1			
5305-282-7659	12	1			
5305-282-8921	8	3			
5305-531-9552	8	1			

Reference No.	Mfr. Code	Figure No.	Item No.
MS16624-4043	96906	6	1
MS20615-3CU4	96906	7	3
MS24692-27	96906	8	4
MS24692-78	96906	6	7
MS35199-1	96906	2	1
MS35226-13	96906	6	3
MS35276-201	96906	3	1
MS35688-2	96906	6	24
MS35689-1	96906	3	11
MS51038-15	96906	2	31

Reference No.	Mfr. Code	Figure No.	Item No.	Reference No.	Mfr. Code	Figure No.	Item No.
MS51038-17	96906	2	29	5178192	19200	11	11
MS51957-1	96906	1	1	5179606	19200	8	1
MS51960-7	96906	2	2	5185119	19200	15	2
MS51960-7	96906	4	7	5315414	00000	9	1
MS51960-8	96906	2	28	5315415	00000	9	2
MS51960-8	96906	4	1	540874	21450	3	8
MS51960-9	96906	3	17	540874	21450	4	4
MS51966-25	96906	2	11	540875	21450	5	1
MS51966-7	96906	6	16	540875	21450	13	1
MS51974-1	96906	6	21	540875	21450	14	1
MS51976-2	96906	3	12	540876	10001	8	6
10555984-3	19200	2	19	540963	21450	10	1
10555982	19200	11	4	540963	21450	12	1
10555983-1	19200	2	22	5631972	19200	9	10
10555983-2	19200	2	24	6016463	19200	5	6
10555983-3	19200	2	25	6138141	19200	S	8
10555983-4	19200	2	26	6138142	19200	9	6
10555984-1	19200	2	17	6138144	19200	6	12
10555984-2	19200	2	18	6138146	19200	6	19
10556748-1	19200	9	3	6138147	19200	14	3
10556748-2	19200	9	4	6188148	19200	14	7
10556748-3	19200	9	5	6138149	19200	10	4
10556749-1	19200	9	7	6138150	19200	13	6
10556749-2	19200	9	8	6138152	19200	3	18
10556749-3	19200	9	9	6138170	19200	3	15
10557488	19200	1	2	6179894	19200	8	9
225414	00000	6	10	6529894	19200	6	25
530880	00000	8	7	6529396	19200	11	12
5032820	19200	5	5	7199579	19200	2	38
5032820	19200	11	5	7199972	19200	11	9
5034658	00000	3	13	7577823	19200	2	27
5034658	00000	6	17	7584003	19200	6	23
5036234	19200	11	7	7631560	19200	6	20
5037821	00000	11	3	7631561	19200	6	18
5039406	00000	8	9	7634685	19200	3	5
503944	00000	2	5	7634723	19200	5	10
5045418	00000	5	3	7635302	19200	2	21
5045419	00000	6	4	7635304	19200	8	5
5045475	19200	3	10	7635305	00000	2	30
5045490	19200	5	7	7636177	19200	6	9
5048144	00000	6	15	7636238	19200	2	16
5048586	00000	8	3	7636577	19200	2	15
5048590	00000	10	2	7640310	19200	15	1
5048595	00000	6	22	7647628	19200	12	3
5048598	19200	4	5	7650547	19200	2	23
5048599	19200	4	8	7654658	19200	2	4
5048600	19200	4	10	7689744	19200	4	6
5048602	19200	11	1	7687244	19200	3	16
5049912	19200	3	20	7687246	19200	3	14
5049913	19200	10	3	7687264	19200	18	4
6049914	19200	13	3	7687265	19200	12	7
5049915	19200	18	5	7687266	19200	2	33
5049917	00000	13	2	7687277	19200	2	3
5049918	00000	14	2	7687278	19200	3	19
5049920	00000	6	6	7687279	19200	2	10
5049925	19200	6	11	7687280	19200	2	12
5049926	00000	3	3	7687281	19200	7	5
5049927	00000	3	2	7687282	19200	2	6
5049929	00000	3	6	7687283	19200	2	7
5049930	00000	3	7	7687285	19200	2	14
6049932	19200	4	2	7687286	19200	6	14
5049933	00000	4	3	7687287	19200	6	8
5049934	00000	5	9	7687288	19200	6	2
5049935	00000	5	2	7687289	19200	7	2
5049938	00000	2	20	7687290	00000	6	5
5049940	19200	2	32	7687291	19200	2	8
5049946	19200	8	4	7687292	19200	2	9
505281	21450	7	1	7687293	19200	7	4

Reference No.	Mfr. Code	Figure No.	Item No.	Reference No.	Mfr. Code	Figure No.	Item No.
7687294	00000	6	4	8289214	19200	12	6
7687296	19200	4	12	8289215	19200	2	35
7691521	19200	15	—	8570118	19200	2	36
8213746	19200	14	5	8570119	19200	12	5
8243174	19200	14	4	8624876-1	19200	2	37
8243175	19200	12	4	8624877	19200	4	11
8243176	19200	2	34	8624877	19200	11	8
8246009	19200	14	6	8624881	19200	11	10

By Order of the Secretary of the Army:

OFFICIAL:
KENNETH G. WICKHAM,
*Major General, United States Army,
The Adjutant General.*

W. C. WESTMORELAND,
*General, United States Army
Chief of Staff.*

Distribution:

To be distributed in accordance with DA Form 12-41 (qty rqr block no. 152) Direct and General Support Maintenance requirements for Telescope Panoramic.

☆ U.S. GOVERNMENT PRINTING OFFICE: 1993 - 342-421/80072

TM 9-1240-236-35P, TELESCOPE PANORAMIC - 1970

TM 9-1240-236-35P

PIN: 026557-000